

PHYSICS

Paper 1 Multiple Choice

9702/12

May/June 2015

1 hour

Additional Materials: Multiple Choice Answer Sheet
Soft clean eraser
Soft pencil (type B or HB is recommended)



READ THESE INSTRUCTIONS FIRST

Write in soft pencil.

Do not use staples, paper clips, glue or correction fluid.

Write your name, Centre number and candidate number on the Answer Sheet in the spaces provided unless this has been done for you.

DO NOT WRITE IN ANY BARCODES.

There are **forty** questions on this paper. Answer **all** questions. For each question there are four possible answers **A, B, C** and **D**.

Choose the **one** you consider correct and record your choice in **soft pencil** on the separate Answer Sheet.

Read the instructions on the Answer Sheet very carefully.

Each correct answer will score one mark. A mark will not be deducted for a wrong answer.

Any working should be done in this booklet.

Electronic calculators may be used.

This document consists of **20** printed pages.

Data

speed of light in free space,	$c = 3.00 \times 10^8 \text{ m s}^{-1}$
permeability of free space,	$\mu_0 = 4\pi \times 10^{-7} \text{ H m}^{-1}$
permittivity of free space,	$\varepsilon_0 = 8.85 \times 10^{-12} \text{ F m}^{-1}$
	$(\frac{1}{4\pi\varepsilon_0} = 8.99 \times 10^9 \text{ m F}^{-1})$
elementary charge,	$e = 1.60 \times 10^{-19} \text{ C}$
the Planck constant,	$h = 6.63 \times 10^{-34} \text{ J s}$
unified atomic mass constant,	$u = 1.66 \times 10^{-27} \text{ kg}$
rest mass of electron,	$m_e = 9.11 \times 10^{-31} \text{ kg}$
rest mass of proton,	$m_p = 1.67 \times 10^{-27} \text{ kg}$
molar gas constant,	$R = 8.31 \text{ J K}^{-1} \text{ mol}^{-1}$
the Avogadro constant,	$N_A = 6.02 \times 10^{23} \text{ mol}^{-1}$
the Boltzmann constant,	$k = 1.38 \times 10^{-23} \text{ J K}^{-1}$
gravitational constant,	$G = 6.67 \times 10^{-11} \text{ N m}^2 \text{ kg}^{-2}$
acceleration of free fall,	$g = 9.81 \text{ m s}^{-2}$

Formulae

uniformly accelerated motion,

$$s = ut + \frac{1}{2}at^2$$

$$v^2 = u^2 + 2as$$

work done on/by a gas,

$$W = p\Delta V$$

gravitational potential,

$$\phi = -\frac{Gm}{r}$$

hydrostatic pressure,

$$p = \rho gh$$

pressure of an ideal gas,

$$p = \frac{1}{3} \frac{Nm}{V} \langle c^2 \rangle$$

simple harmonic motion,

$$a = -\omega^2 x$$

velocity of particle in s.h.m.,

$$v = v_0 \cos \omega t$$

$$v = \pm \omega \sqrt{(x_0^2 - x^2)}$$

electric potential,

$$V = \frac{Q}{4\pi\epsilon_0 r}$$

capacitors in series,

$$1/C = 1/C_1 + 1/C_2 + \dots$$

capacitors in parallel,

$$C = C_1 + C_2 + \dots$$

energy of charged capacitor,

$$W = \frac{1}{2}QV$$

resistors in series,

$$R = R_1 + R_2 + \dots$$

resistors in parallel,

$$1/R = 1/R_1 + 1/R_2 + \dots$$

alternating current/voltage,

$$x = x_0 \sin \omega t$$

radioactive decay,

$$x = x_0 \exp(-\lambda t)$$

decay constant,

$$\lambda = \frac{0.693}{t_{\frac{1}{2}}}$$

- 1 Which definition is correct and uses only quantities rather than units?
- A Density is mass per cubic metre.
 - B Potential difference is energy per unit current.
 - C Pressure is force per unit area.
 - D Speed is distance travelled per second.
- 2 The average kinetic energy E of a gas molecule is given by the equation

$$E = \frac{3}{2} kT$$

where T is the absolute (kelvin) temperature.

What are the SI base units of k ?

- A $\text{kg}^{-1} \text{m}^{-1} \text{s}^2 \text{K}$
- B $\text{kg}^{-1} \text{m}^{-2} \text{s}^2 \text{K}$
- C $\text{kg m s}^{-2} \text{K}^{-1}$
- D $\text{kg m}^2 \text{s}^{-2} \text{K}^{-1}$

- 3 An analogue ammeter has a pointer which moves over a scale. Following prolonged use, the pointer does not return fully to zero when the current is turned off and the meter has become less sensitive at higher currents than it is at lower currents.

Which diagram best represents the calibration graph needed to obtain an accurate current reading?

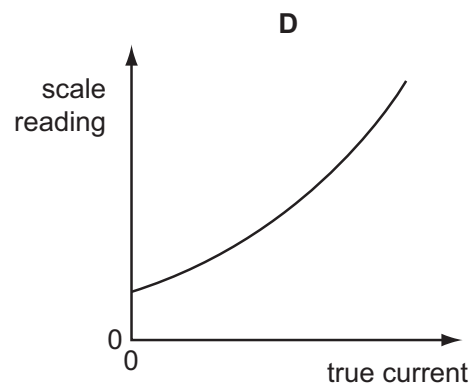
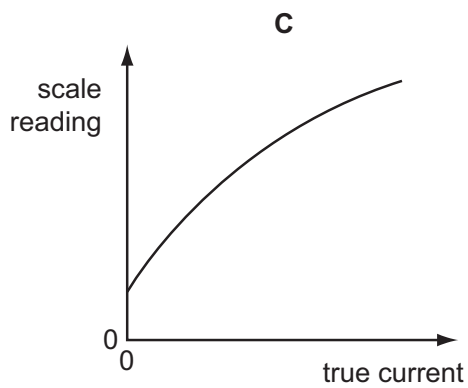
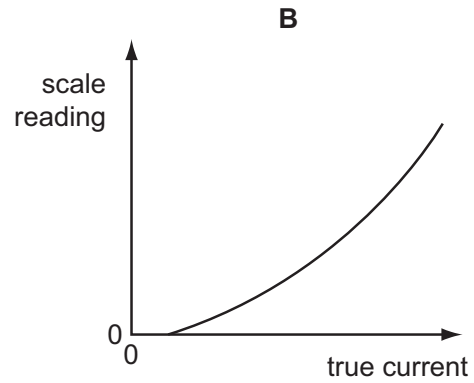
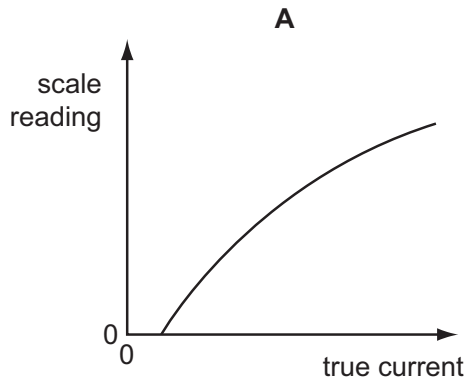

- 4 The arrow represents the vector R .



Which diagram does **not** represent R as two perpendicular components?

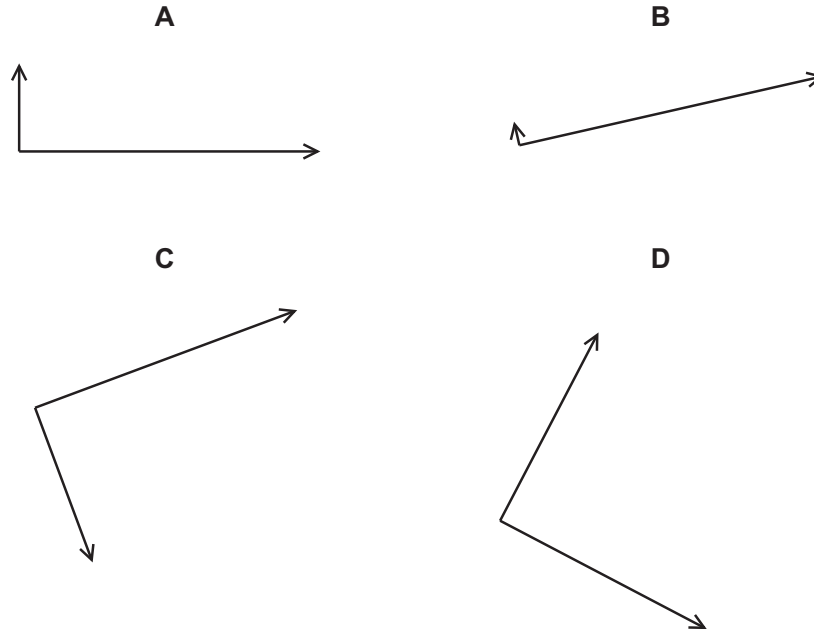

- 5 A power supply of electromotive force (e.m.f.) 50 V and negligible internal resistance is connected in series with resistors of resistance $100\ \Omega$ and $5\ \Omega$, as shown.

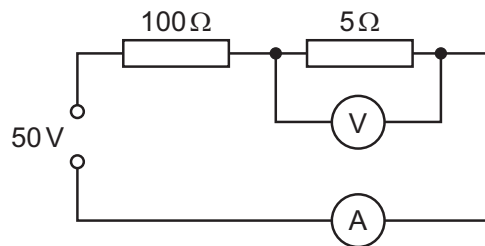

A voltmeter measures the potential difference (p.d.) across the $5\ \Omega$ resistor and an ammeter measures the current in the circuit.

What are suitable ranges for the ammeter and for the voltmeter?

	ammeter range/A	voltmeter range/V
A	0–0.1	0–1
B	0–0.1	0–3
C	0–1.0	0–1
D	0–1.0	0–3

- 6 A single sheet of aluminium foil is folded twice to produce a stack of four sheets. The total thickness of the stack of sheets is measured to be (0.80 ± 0.02) mm. This measurement is made using a digital caliper with a zero error of (-0.20 ± 0.02) mm.

What is the percentage uncertainty in the calculated thickness of a single sheet?

- A 1.0% B 2.0% C 4.0% D 6.7%

- 7 In an experiment to determine the acceleration of free fall g , a ball bearing is held by an electromagnet. When the current to the electromagnet is switched off, a clock starts and the ball bearing falls. After falling a distance h , the ball bearing strikes a switch to stop the clock which measures the time t of the fall.

If systematic errors cause t and h to be measured incorrectly, which error **must** cause g to appear greater than 9.81 ms^{-2} ?

- A h measured as being **smaller** than it actually is and t is measured correctly
 B h measured as being **smaller** than it actually is and t measured as being **larger** than it actually is
 C h measured as being **larger** than it actually is and t measured as being **larger** than it actually is
 D h is measured correctly and t measured as being **smaller** than it actually is
- 8 A stone is thrown horizontally from the top of a cliff. Air resistance is negligible.

Which graph shows the variation with time of the vertical component of the stone's velocity?

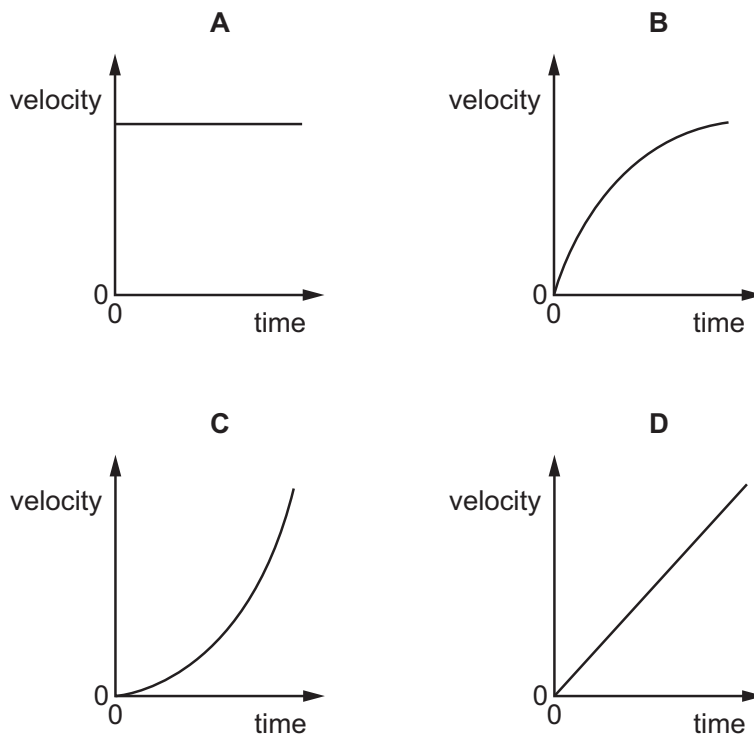

- 9 A sprinter runs a 100 m race in a straight line. He accelerates from the starting block at a constant acceleration of 2.5 m s^{-2} to reach his maximum speed of 10 m s^{-1} . He maintains this speed until he crosses the finish line.

Which time does it take the sprinter to run the race?

- A 4 s B 10 s C 12 s D 20 s

- 10 A firework rocket is fired vertically upwards. The fuel burns and produces a constant upwards force on the rocket. After 5 seconds there is no fuel left. Air resistance is negligible.

What is the acceleration before and after 5 seconds?

	before 5 seconds	after 5 seconds
A	constant	constant
B	constant	zero
C	increasing	constant
D	increasing	zero

- 11 Trolley X, moving along a horizontal frictionless track, collides with a stationary trolley Y. The two trolleys become attached and move off together.

Which statement about this interaction is correct?

- A Some of the kinetic energy of trolley X is changed to momentum in the collision.
 B Some of the momentum of trolley X is changed to kinetic energy in the collision.
 C Trolley X loses some of its momentum as heat in the collision.
 D Trolley X shares its momentum with trolley Y but some of its kinetic energy is lost.

- 12 An astronaut throws a stone with a horizontal velocity near to the Moon's surface.

Which row describes the horizontal and vertical forces acting on the stone after release?

	horizontal force	vertical force
A	constant	constant
B	constant	decreasing
C	zero	constant
D	zero	decreasing

- 13 Newton's third law of motion is often summarised as 'Every action (force) has an equal and opposite reaction.'

A book rests on a table.

If the weight of the book is the 'action' force, what is the 'reaction' force?

- A** the pull of the book on the Earth
B the pull of the Earth on the book
C the push of the book on the table
D the push of the table on the book
- 14 A ladder is positioned on icy (frictionless) ground and is leant against a rough wall. At the instant of release it begins to slide.

Which diagram correctly shows the directions of the forces P , W and R acting on the ladder as it slides?

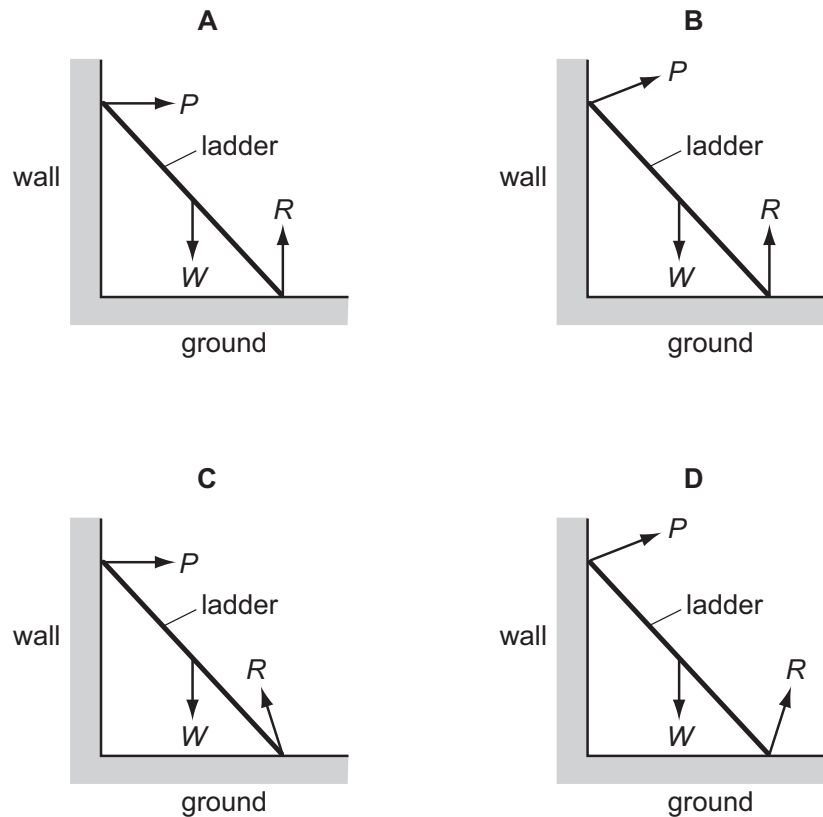

- 15 A uniform solid block has weight 500 N, width 0.4 m and height 0.6 m. The block rests on the edge of a step of depth 0.8 m, as shown.

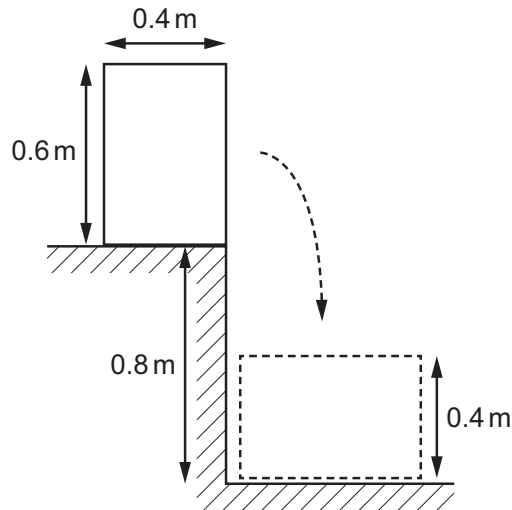

The block is knocked over the edge of the step and rotates through 90° before coming to rest with the 0.6 m edge horizontal.

What is the change in gravitational potential energy of the block?

- A 300 J B 400 J C 450 J D 550 J
- 16 The diagram shows a hydroelectric power station.
The reservoir is linked to the turbines by a pipe of uniform cross-sectional area.

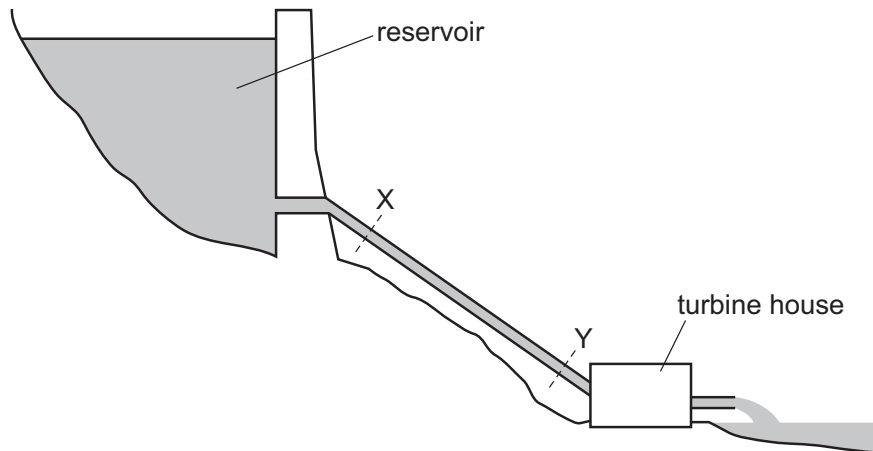

Water flows from X to Y at constant speed. Which statement about the change of energy of the water as it moves from X to Y is correct?

- A It gains both gravitational potential energy and kinetic energy.
B It loses both elastic potential energy and kinetic energy.
C It loses both elastic potential energy and gravitational potential energy.
D It loses gravitational potential energy and gains elastic potential energy.

- 17 A fisherman lifts a fish of mass 250 g from rest through a vertical height of 1.8 m. The fish gains a speed of 1.1 m s^{-1} .

What is the energy gained by the fish?

- A 0.15 J B 4.3 J C 4.4 J D 4.6 J

- 18 Water from a reservoir is fed to the turbine of a hydroelectric system at a rate of 500 kg s^{-1} . The reservoir is 300 m above the level of the turbine.

The electrical output from the generator driven by the turbine is 200 A at a potential difference of 6000 V.

What is the efficiency of the system?

- A 8.0% B 8.2% C 80% D 82%

- 19 Which row correctly describes the ordering and motion of the molecules in liquid water and in ice when both are at a temperature of 0°C ?

	ordering	motion
A	a regular pattern of molecules in ice but not in water	molecules in both ice and water have the same average speed
B	a regular pattern of molecules in ice but not in water	molecules in ice travel more slowly than those in water
C	a regular pattern of molecules in both ice and water	molecules in ice travel more slowly than those in water
D	a regular pattern of molecules in both ice and water	molecules in both ice and water have the same average speed

- 20 The maximum pressure that granite rock can withstand is $2.0 \times 10^8 \text{ N m}^{-2}$. Above this pressure, the rock begins to flow like a liquid. The density of granite is $2.7 \times 10^3 \text{ kg m}^{-3}$.

What would be the height of a pure granite mountain whose base is just beginning to flow?

- A $3.8 \times 10^3 \text{ m}$ B $7.6 \times 10^3 \text{ m}$ C $3.7 \times 10^4 \text{ m}$ D $7.4 \times 10^4 \text{ m}$

21 To determine the Young modulus of a wire, several measurements are taken.

In which row can the measurement **not** be taken **directly** with the stated apparatus?

	measurement	apparatus
A	area of cross-section of wire	micrometer screw gauge
B	extension of wire	vernier scale
C	mass of load applied to wire	electronic balance
D	original length of wire	metre rule

22 A long, thin metal wire is suspended from a fixed support and hangs vertically. Masses are suspended from its lower end.

The load on the lower end is increased from zero and then decreased again back to zero.

The diagram shows the force-extension graph produced.

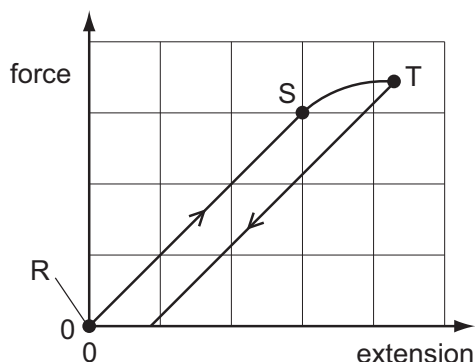

Where on the graph would the elastic limit be found?

- A** anywhere between point R and point S
- B** just beyond point S
- C** exactly at point S
- D** exactly at point T

- 23 The diagram represents a steel tube with wall thickness w which is small in comparison with the diameter of the tube.

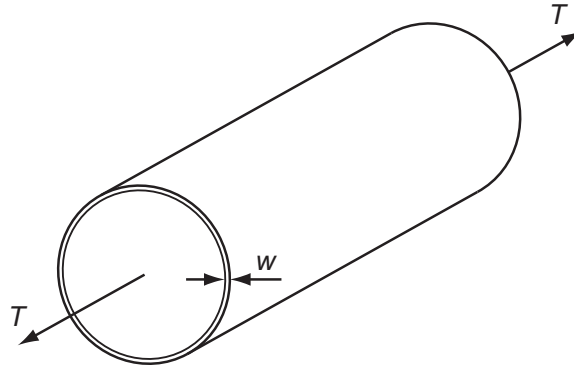

The tube is under tension, caused by a force T , parallel to the axis of the tube. To reduce the stress in the material of the tube, it is proposed to thicken the wall.

The tube diameter and the tension being constant, which wall thickness gives half the stress?

- A $\frac{w}{2}$ B $\sqrt{2}w$ C $2w$ D $4w$
- 24 Two light waves of the same frequency are represented by the diagram.

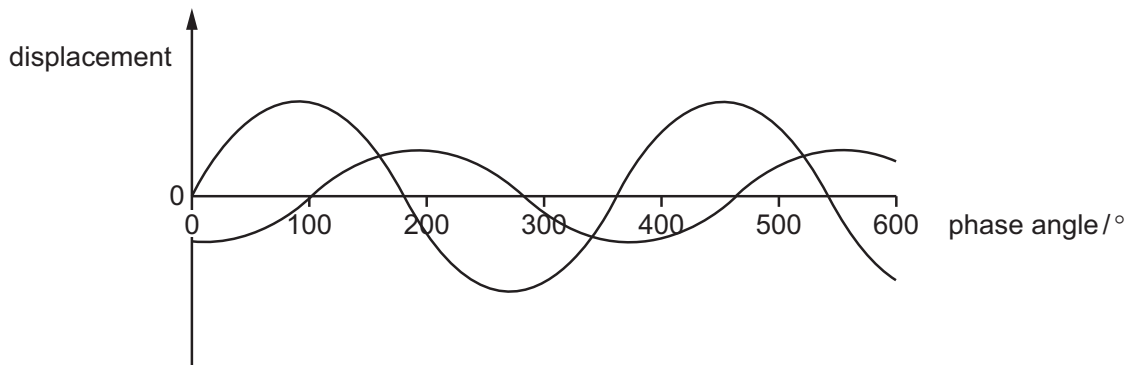

What could be the phase difference between the two waves?

- A 150° B 220° C 260° D 330°
- 25 A sound wave has a speed of 330 m s^{-1} and a frequency of 50 Hz .

What is a possible distance between two points on the wave that have a phase difference of 60° ?

- A 0.03 m B 1.1 m C 2.2 m D 6.6 m

- 26 What is **not** an **essential** condition for an observable interference pattern to occur between the waves from two sources?
- A The frequencies of the two sources must be equal.
 - B The sources must be coherent.
 - C The sources must emit waves of equal amplitude.
 - D The waves from the two sources must overlap.
- 27 Source S emits microwaves with a constant amplitude. The microwaves hit a metal screen P and are reflected. A stationary wave is formed between S and P. The wavelength of the microwaves is much smaller than the distance between S and P.

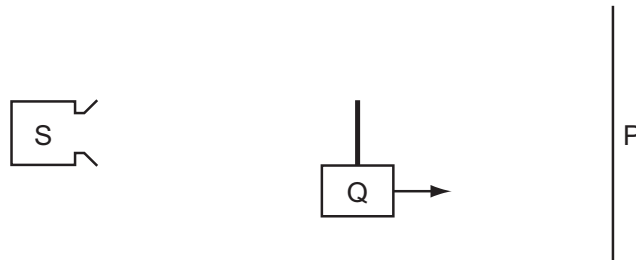

A detector Q is moved at a slow, constant speed from S to P.

What happens to the amplitude of the signal detected by Q?

- A decreases steadily
- B increases and decreases regularly
- C increases steadily
- D remains constant

- 28 A pattern of waves was observed without being able to view the source of the waves. The pattern is represented in the diagram.

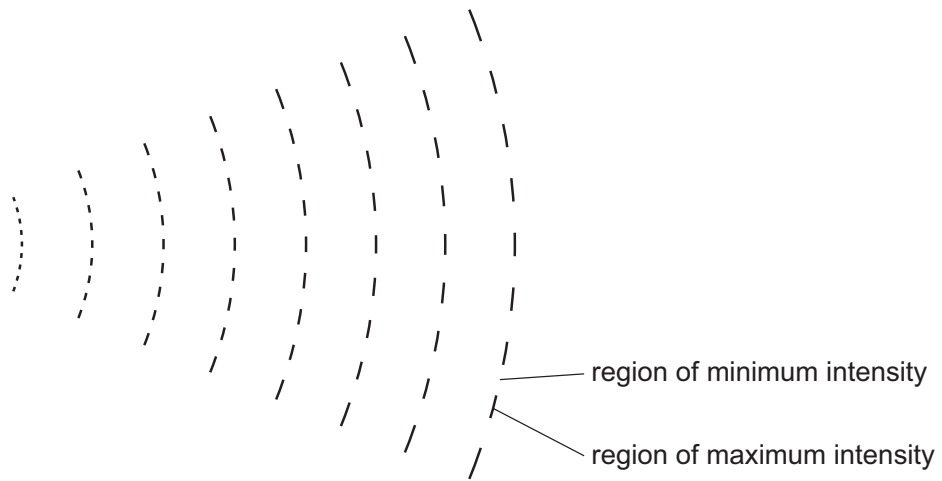

What can cause this pattern?

- A coherence only
- B diffraction and interference
- C diffraction only
- D interference only

- 29 A positive charge and a negative charge of equal magnitude are placed a short distance apart.

Which diagram best represents the associated electric field?

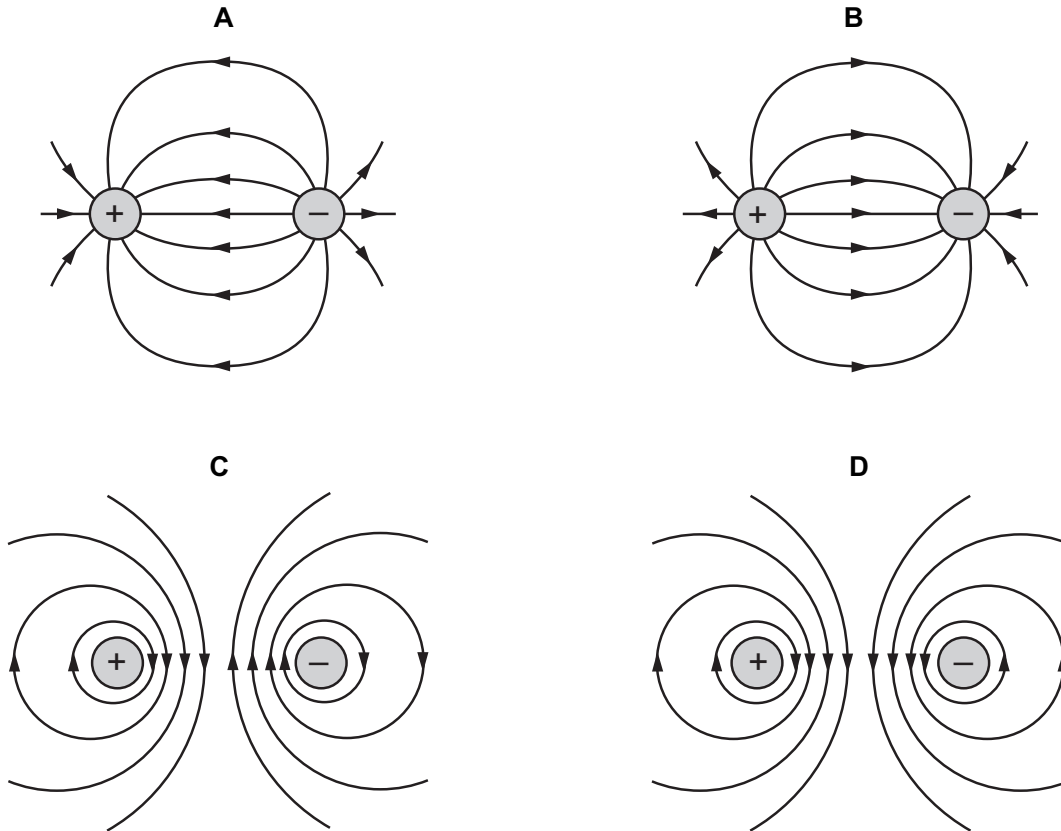

- 30 A charged oil drop of mass m , with n excess electrons, is held stationary in the uniform electric field between two horizontal plates separated by a distance d .

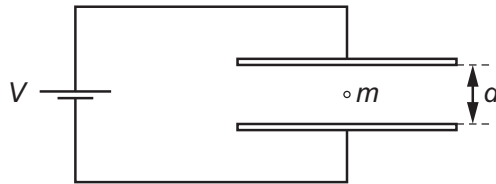

The voltage between the plates is V , the elementary charge is e and the acceleration of free fall is g .

What is the value of n ?

- A $\frac{eV}{mgd}$ B $\frac{mgd}{eV}$ C $\frac{meV}{gd}$ D $\frac{gd}{meV}$

31 Which unit is **not** used in either the definition of the coulomb or the definition of the volt?

- A ampere
- B joule
- C ohm
- D second

32 When a thin metal wire is stretched, it becomes longer and thinner. This causes a change in the resistance of the wire. The volume of the wire remains constant.

Which graph could represent the variation with extension x of the resistance R of the wire?

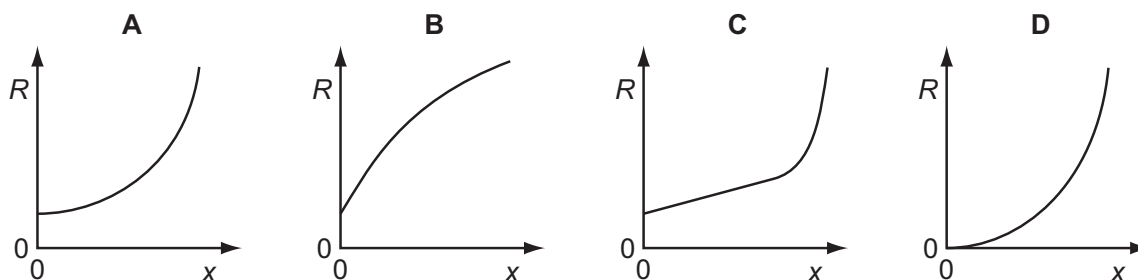

33 Which statement is **not** valid?

- A Current is the speed of the charged particles that carry it.
- B Electromotive force (e.m.f.) is the energy converted to electrical energy from other forms per unit charge.
- C The potential difference (p.d.) between two points is the work done per unit charge when moving charge from one point to the other.
- D The resistance between two points is the p.d. between the two points per unit current.

34 A cell of e.m.f. E delivers a charge Q to an external circuit.

Which statement is correct?

- A The energy dissipation in the external circuit is EQ .
- B The energy dissipation within the cell is EQ .
- C The external resistance is EQ .
- D The total energy dissipation in the cell and the external circuit is EQ .

35 Each of Kirchhoff's two laws presumes that some quantity is conserved.

Which row states Kirchhoff's **first** law and names the quantity that is conserved?

	statement	quantity
A	the algebraic sum of currents into a junction is zero	charge
B	the algebraic sum of currents into a junction is zero	energy
C	the e.m.f. in a loop is equal to the algebraic sum of the product of current and resistance round the loop	charge
D	the e.m.f. in a loop is equal to the algebraic sum of the product of current and resistance round the loop	energy

- 36 A potential divider circuit consists of fixed resistors of resistance 2.0Ω and 4.0Ω connected in series with a 3.0Ω resistor fitted with a sliding contact. These are connected across a battery of e.m.f. 9.0V and zero internal resistance, as shown.

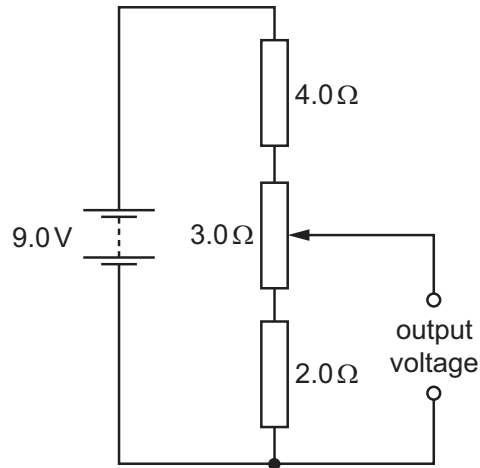

What are the maximum and the minimum output voltages of this potential divider circuit?

	maximum voltage /V	minimum voltage /V
A	4.0	2.0
B	5.0	2.0
C	9.0	0
D	9.0	2.0

- 37 A cell of e.m.f. 2.0V and negligible internal resistance is connected to a network of resistors as shown.

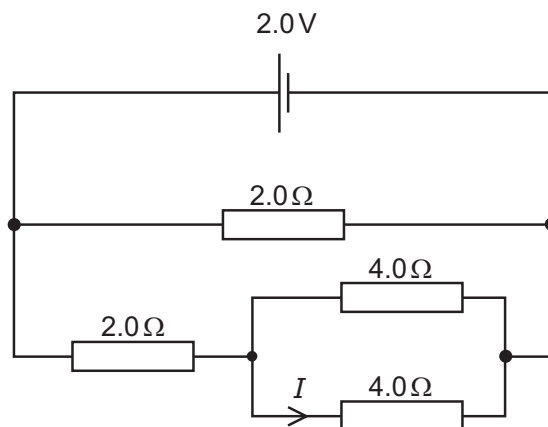

What is the current I ?

- A** 0.25A **B** 0.33A **C** 0.50A **D** 1.5A

- 38 An experiment in which α -particles were deflected by a gold foil produced new insights into the structure of the atom.

Which conclusion can be drawn from the results of the experiment?

- A Atomic nuclei occupy a very small fraction of the volume of an atom.
 - B Electrons orbit the atomic nucleus.
 - C Some atoms of the same element contain different numbers of neutrons.
 - D The atomic nucleus contains protons and neutrons.
- 39 A radioactive substance contains a number of identical nuclei that emit β -particles.

Which property of these nuclei remains unaltered by the emission?

- A charge
 - B neutron number
 - C nucleon number
 - D proton number
- 40 A uranium-238 nucleus, ${}_{92}^{238}\text{U}$, undergoes nuclear decays to form uranium-234, ${}_{92}^{234}\text{U}$.

Which series of decays could give this result?

- A emission of four β -particles
- B emission of four γ -rays
- C emission of one α -particle and two β -particles
- D emission of two α -particles and eight β -particles

Permission to reproduce items where third-party owned material protected by copyright is included has been sought and cleared where possible. Every reasonable effort has been made by the publisher (UCLES) to trace copyright holders, but if any items requiring clearance have unwittingly been included, the publisher will be pleased to make amends at the earliest possible opportunity.

To avoid the issue of disclosure of answer-related information to candidates, all copyright acknowledgements are reproduced online in the Cambridge International Examinations Copyright Acknowledgements Booklet. This is produced for each series of examinations and is freely available to download at www.cie.org.uk after the live examination series.

Cambridge International Examinations is part of the Cambridge Assessment Group. Cambridge Assessment is the brand name of University of Cambridge Local Examinations Syndicate (UCLES), which is itself a department of the University of Cambridge.