

Cambridge International AS & A Level

PHYSICS

9702/12

Paper 1 Multiple Choice

October/November 2023

1 hour 15 minutes

You must answer on the multiple choice answer sheet.

You will need: Multiple choice answer sheet
Soft clean eraser
Soft pencil (type B or HB is recommended)

INSTRUCTIONS

- There are **forty** questions on this paper. Answer **all** questions.
- For each question there are four possible answers **A, B, C** and **D**. Choose the **one** you consider correct and record your choice in soft pencil on the multiple choice answer sheet.
- Follow the instructions on the multiple choice answer sheet.
- Write in soft pencil.
- Write your name, centre number and candidate number on the multiple choice answer sheet in the spaces provided unless this has been done for you.
- Do **not** use correction fluid.
- Do **not** write on any bar codes.
- You may use a calculator.

INFORMATION

- The total mark for this paper is 40.
- Each correct answer will score one mark.
- Any rough working should be done on this question paper.

This document has **20** pages. Any blank pages are indicated.



Data

acceleration of free fall	$g = 9.81 \text{ m s}^{-2}$
speed of light in free space	$c = 3.00 \times 10^8 \text{ m s}^{-1}$
elementary charge	$e = 1.60 \times 10^{-19} \text{ C}$
unified atomic mass unit	$1 \text{ u} = 1.66 \times 10^{-27} \text{ kg}$
rest mass of proton	$m_p = 1.67 \times 10^{-27} \text{ kg}$
rest mass of electron	$m_e = 9.11 \times 10^{-31} \text{ kg}$
Avogadro constant	$N_A = 6.02 \times 10^{23} \text{ mol}^{-1}$
molar gas constant	$R = 8.31 \text{ J K}^{-1} \text{ mol}^{-1}$
Boltzmann constant	$k = 1.38 \times 10^{-23} \text{ J K}^{-1}$
gravitational constant	$G = 6.67 \times 10^{-11} \text{ N m}^2 \text{ kg}^{-2}$
permittivity of free space	$\epsilon_0 = 8.85 \times 10^{-12} \text{ F m}^{-1}$ $(\frac{1}{4\pi\epsilon_0} = 8.99 \times 10^9 \text{ m F}^{-1})$
Planck constant	$h = 6.63 \times 10^{-34} \text{ J s}$
Stefan–Boltzmann constant	$\sigma = 5.67 \times 10^{-8} \text{ W m}^{-2} \text{ K}^{-4}$

Formulae

uniformly accelerated motion	$s = ut + \frac{1}{2}at^2$ $v^2 = u^2 + 2as$
hydrostatic pressure	$\Delta p = \rho g \Delta h$
upthrust	$F = \rho g V$
Doppler effect for sound waves	$f_o = \frac{f_s v}{v \pm v_s}$
electric current	$I = Anvq$
resistors in series	$R = R_1 + R_2 + \dots$
resistors in parallel	$\frac{1}{R} = \frac{1}{R_1} + \frac{1}{R_2} + \dots$

- 1 A student estimates the maximum speed of some different moving objects.

Which maximum speed is **not** a reasonable estimate?

- A container ship: 10 m s^{-1}
B Olympic sprinter: 0.1 km s^{-1}
C racing car: 9000 cm s^{-1}
D snail: 0.01 km h^{-1}
- 2 Which quantity is an SI base quantity?
- A force
B newton
C second
D time
- 3 A student takes measurements to determine the constant acceleration of a model car moving from rest in a straight line. The measured values with their absolute uncertainties are shown.

quantity	measured value	uncertainty
displacement	16.5 m	$\pm 0.1 \text{ m}$
time	15.0 s	$\pm 1.0 \text{ s}$

The student uses the equation $s = \frac{1}{2}at^2$ to calculate the acceleration of the car.

What is the acceleration and its absolute uncertainty?

- A $(0.11 \pm 0.01) \text{ m s}^{-2}$
B $(0.11 \pm 0.02) \text{ m s}^{-2}$
C $(0.15 \pm 0.01) \text{ m s}^{-2}$
D $(0.15 \pm 0.02) \text{ m s}^{-2}$

- 4 An aeroplane is moving at a constant speed in a straight line at an angle θ to the horizontal. Four forces act on the aeroplane: thrust force T , weight W , lift force L and resistive force R .

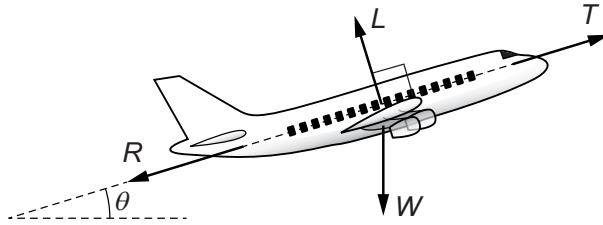

Which two equations must be correct?

- A $L = W \cos \theta$ and $T = R + W \sin \theta$
 B $L = W \sin \theta$ and $T = R + W \cos \theta$
 C $L = W \cos \theta$ and $T = R - W \sin \theta$
 D $L = W \sin \theta$ and $T = R - W \cos \theta$
- 5 What is the definition of acceleration?
- A the rate of change of displacement
 B the rate of change of kinetic energy
 C the rate of change of momentum
 D the rate of change of velocity
- 6 An astronaut on the Moon, where there is no air resistance, throws a ball. The ball's initial velocity has a vertical component of 8.00 m s^{-1} and a horizontal component of 4.00 m s^{-1} , as shown.

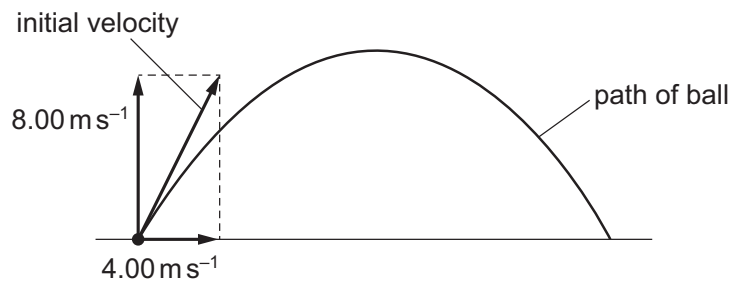

The acceleration of free fall on the Moon is 1.62 m s^{-2} .

What is the speed of the ball 9.00 s after being thrown?

- A 6.58 m s^{-1} B 7.70 m s^{-1} C 10.6 m s^{-1} D 14.6 m s^{-1}

- 7 Two blocks, of mass 0.20 kg and 0.50 kg, are connected by a light inextensible string that passes over a frictionless pulley.

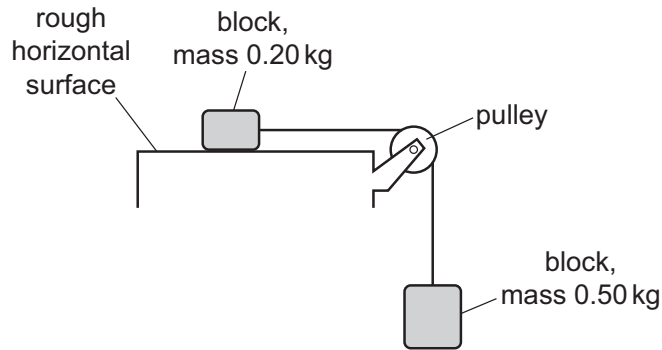

The blocks are initially held stationary. The block of mass 0.20 kg rests on a rough horizontal surface.

The block of mass 0.50 kg is suspended in air. Air resistance is negligible.

When the blocks are released, they have an acceleration of magnitude 2.0 m s^{-2} .

What is the magnitude of the frictional force between the block of mass 0.20 kg and the rough surface?

- A** 3.5 N **B** 3.9 N **C** 4.5 N **D** 6.3 N
- 8 A resultant force causes an object to accelerate.
- What is equal to the resultant force?
- A** the acceleration of the object per unit mass
B the change in kinetic energy of the object per unit time
C the change in momentum of the object per unit time
D the change in velocity of the object per unit time
- 9 An object falls from a stationary helicopter and reaches terminal velocity.

What happens to the acceleration of the object between leaving the helicopter and reaching terminal velocity?

- A** It decreases to 9.81 m s^{-2} .
B It decreases to zero.
C It increases to 9.81 m s^{-2} .
D It remains constant at 9.81 m s^{-2} .

- 10 Two balls, of masses m and $2m$, travelling in a vacuum with initial velocities $2v$ and v respectively, collide with each other head-on, as shown.

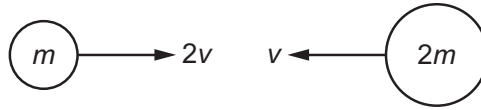

After the collision, the ball of mass m rebounds to the left with velocity v .

What is the loss of kinetic energy in the collision?

- A $\frac{3}{4}mv^2$ B $\frac{3}{2}mv^2$ C $\frac{9}{4}mv^2$ D $\frac{9}{2}mv^2$
- 11 A force F is applied at an angle of 45° to a door handle at a distance d from the pivot of the handle, as shown.

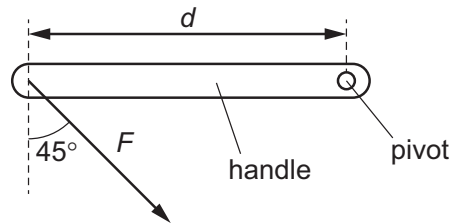

What is the moment of the force about the pivot?

- A $\frac{Fd}{\sqrt{2}}$ B Fd C $Fd\sqrt{2}$ D $2Fd$
- 12 A couple consists of two forces, each of magnitude F , that act in opposite directions in the same plane.

The perpendicular distance between the two forces is d .

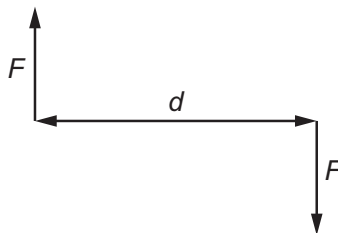

What is the torque of the couple?

- A $\frac{Fd}{2}$ B $\frac{F}{d}$ C Fd D $2Fd$

- 13 The diagram shows an experiment to determine the force exerted on a ball by a horizontal air flow.

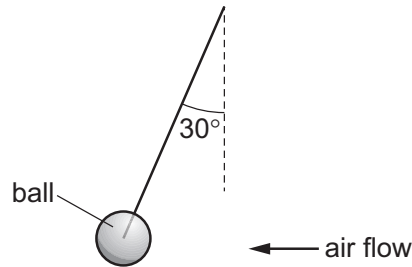

The ball is suspended by a light string and weighs 0.15 N.

The deflection of the string from vertical is 30° . The ball is in equilibrium.

What is the force on the ball from the air flow?

- A** 0.075 N **B** 0.087 N **C** 0.26 N **D** 0.30 N
- 14 Two solid cylindrical objects X and Y are held fully submerged in a liquid, as shown.

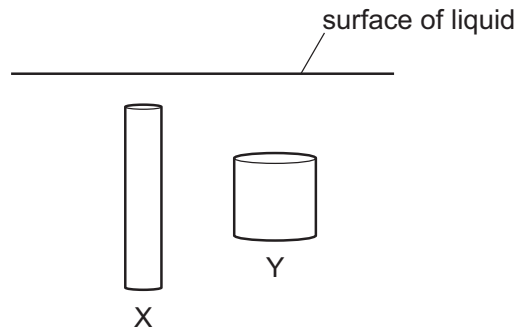

The objects have the same volume. The density of the material of Y is twice the density of the material of X. Both objects are stationary.

Which statement is correct?

- A** The force due to the liquid acting on the top surface of X is greater than that acting on the top surface of Y.
- B** The pressure difference due to the liquid between the top and bottom surfaces of X is the same as that for Y.
- C** The upthrust acting on X is the same as the upthrust acting on Y.
- D** The weight of X is the same as the weight of Y.

- 15 An electric car travels at a constant speed of 70 km h^{-1} for 80 km on a straight horizontal road and uses energy E from its battery.

The total resistive force acting on the car is proportional to $(\text{speed})^2$. Assume that the electric motor is 100% efficient.

How much energy is used from the battery when the car travels at a constant speed of 60 km h^{-1} for 80 km on the straight horizontal road?

- A $0.73E$ B $0.86E$ C $1.2E$ D $1.4E$
- 16 What is meant by the efficiency of a system?
- A the total energy input to the system divided by the useful energy output by the system
B the useful energy output from the system divided by the energy wasted by the system
C the useful energy output from the system divided by the total energy input to the system
D the energy wasted by the system divided by the total energy input to the system
- 17 When an object of mass m is raised through a vertical height Δh , the gain of its gravitational potential energy is ΔE_p .

ΔE_p and Δh are related by the equation

$$\Delta E_p = mg\Delta h,$$

where g is the acceleration of free fall.

The definition of which physical quantity is needed to derive this equation?

- A acceleration
B momentum
C power
D work done

- 18 Three identical springs, each with the same spring constant, are connected together in four different arrangements, as shown.

Which arrangement has the largest combined spring constant?

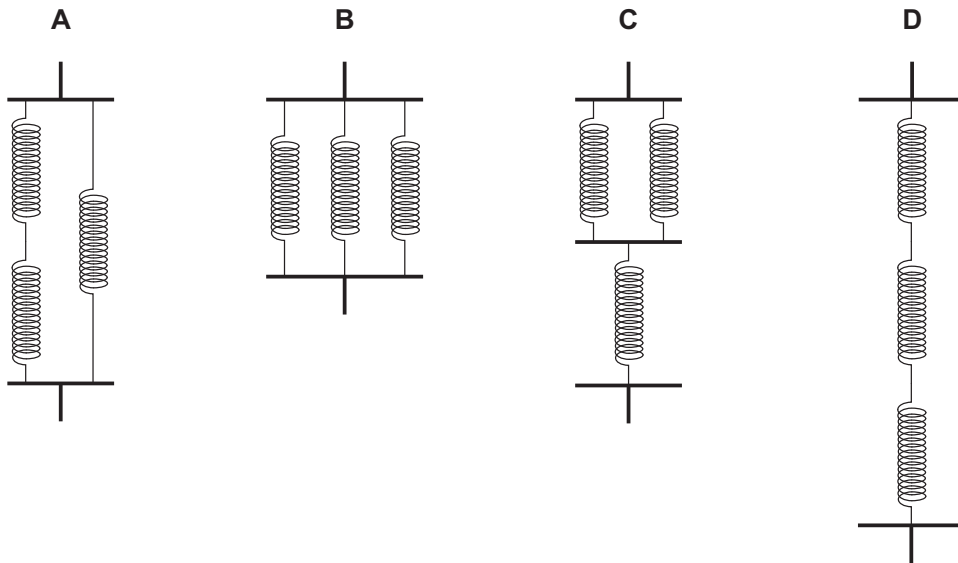

- 19 The force–extension graph for a wire is shown.

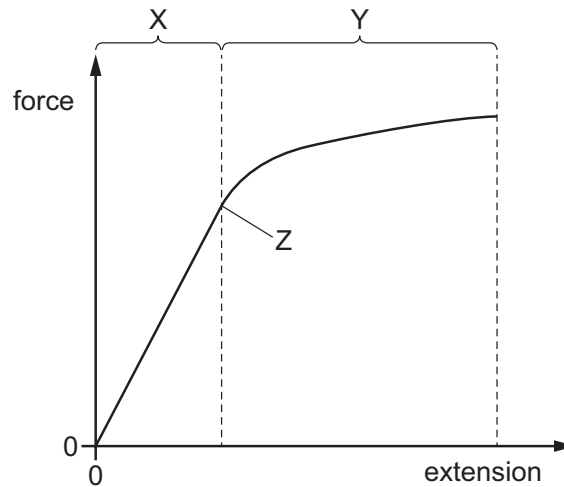

Which row could identify the labels X, Y and Z?

	limit of proportionality	region of elastic deformation	region of plastic deformation
A	X	Y	Z
B	Z	Y	X
C	Y	Z	X
D	Z	X	Y

- 20 X and Y are two points on the surface of water in a ripple tank. A source of constant frequency generates a wave which travels past X and Y, causing them to oscillate vertically.

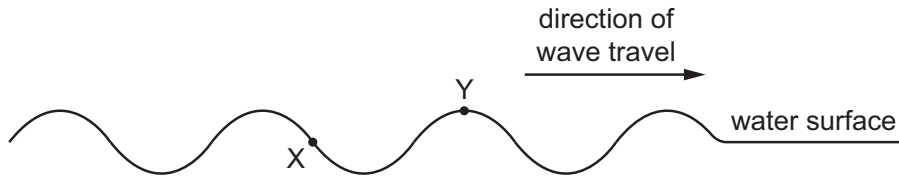

What is the phase difference between X and Y?

- A 45° B 135° C 180° D 270°
- 21 A transverse wave on a rope has wavelength λ and period T .

The graph shows the variation of the displacement of the particles of the rope with distance in the direction of travel of the wave at time $t = 0$.

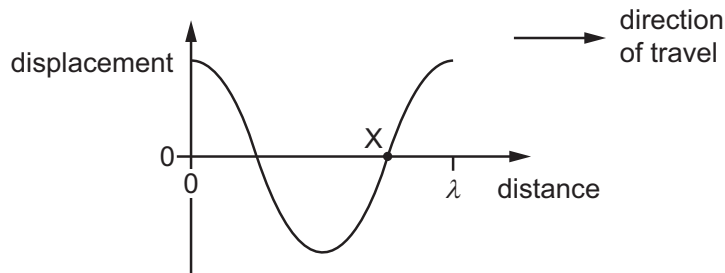

A particle X is labelled.

Which graph shows the variation of the displacement of particle X with time t ?

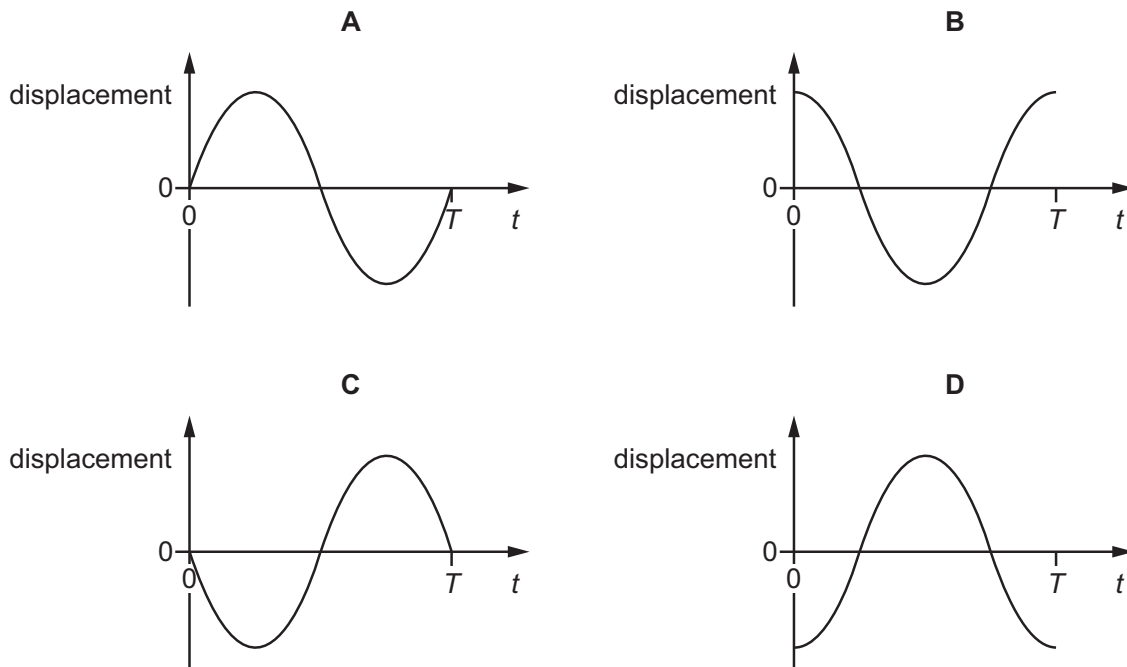

- 22 A source of sound waves is moving at a constant speed directly towards a stationary observer.

The sound waves have a speed of 340 ms^{-1} and a frequency of 480 Hz . The observer hears sound waves of frequency 650 Hz .

What is the speed of the source?

- A 89 ms^{-1} B 120 ms^{-1} C 250 ms^{-1} D 340 ms^{-1}

- 23 A student is investigating two electromagnetic waves, X and Y, in a vacuum.

Wave X has a wavelength of $5.2 \times 10^{-7} \text{ m}$. Wave Y has a frequency of 9.4 GHz .

Which principal regions of the electromagnetic spectrum contain waves X and Y?

	X	Y
A	radio wave	ultraviolet
B	ultraviolet	visible
C	visible	microwave
D	microwave	radio wave

- 24 A plane polarised light wave of intensity I_0 is incident normally on a polarising filter. The initial intensity of the transmitted wave is 0.

A second polarising filter is then inserted between the source and the first filter. Its transmission axis is at 45° to the transmission axis of the first filter, as shown.

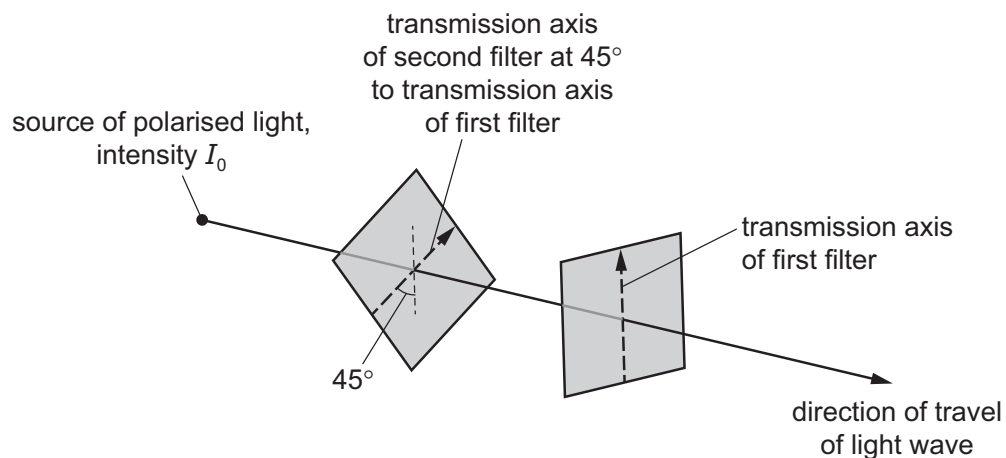

What is the intensity of the transmitted wave from the filter combination?

- A 0 B $\frac{I_0}{8}$ C $\frac{I_0}{4}$ D $\frac{I_0}{2}$

25 What can explain how stationary waves are formed from progressive waves?

- A diffraction
- B polarisation
- C superposition
- D the Doppler effect

26 A pipe has a length of 2.0 m. It is open at one end and closed at the other end.

A stationary sound wave is set up within the pipe. There are four nodes (N) and four antinodes (A) within the length of the pipe.



What is the wavelength of the sound wave?

- A 0.57 m
- B 1.1 m
- C 1.3 m
- D 1.6 m

27 A teacher is explaining diffraction to a group of students.

Which piece of apparatus is most appropriate for the teacher to use to demonstrate diffraction?

- A a long spring
- B a ripple tank
- C a rope
- D a stretched string

- 28 Coherent light of constant wavelength is incident normally on a double slit. Interference fringes are formed on a screen that is a fixed distance from the double slit. The screen is parallel to the double slit.

The separation of the slits is varied.

Which graph best shows the variation with slit separation a of the spacing x of the interference fringes?

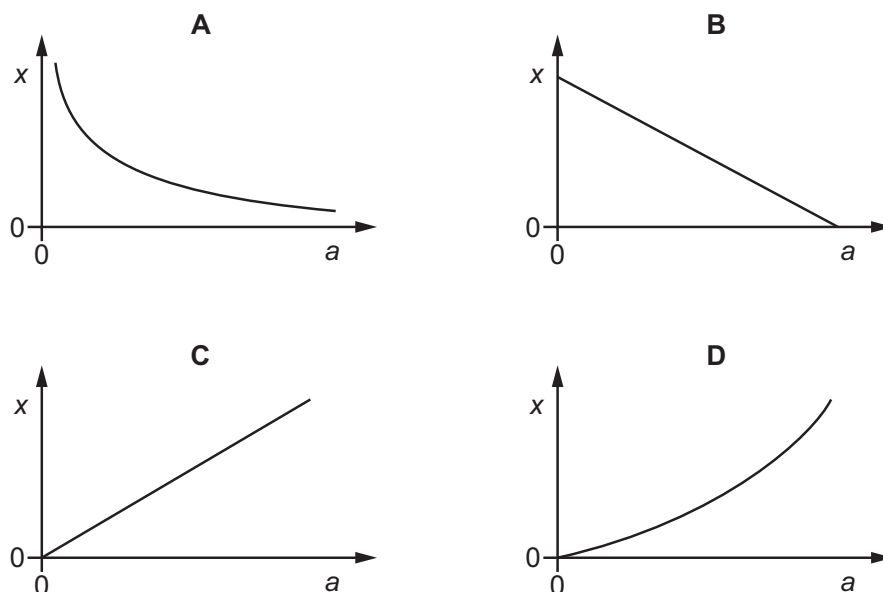

- 29 Light of wavelength 690 nm passes through a diffraction grating with 300 lines per mm, producing a series of bright spots (maxima) on a screen.

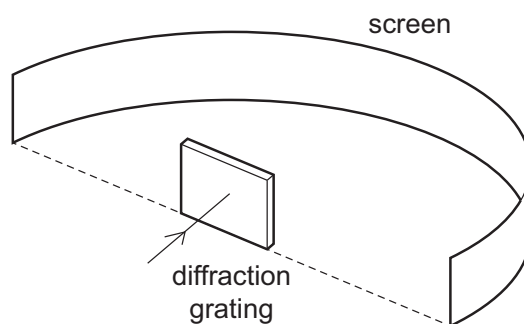

What is the total number of bright spots that are produced?

- A** 4 **B** 5 **C** 8 **D** 9

- 30 A fine mist of oil droplets is sprayed into air. As the oil droplets leave the nozzle of the spraying device they can become electrically charged.

What is **not** a possible value for the charge on an oil droplet?

- A zero
 B $1.0 \times 10^{-19} \text{ C}$
 C $4.8 \times 10^{-19} \text{ C}$
 D $8.0 \times 10^{-19} \text{ C}$
- 31 In the circuit shown, a fixed resistor X is connected in series with a battery and a variable resistor.

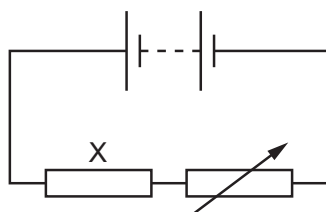

The power dissipated in resistor X is 7.2 W when a current of 3.0 A passes through it.

The variable resistor is adjusted so that the power dissipated in X increases by 50%.

What is the new current in the circuit?

- A 2.4 A B 3.7 A C 4.5 A D 14 A
- 32 The potential difference across a metal wire is kept constant. The length l and the diameter d of the wire are both varied. The type of metal is kept the same.

How is the current in the wire related to l and d ?

- A It is directly proportional to l and inversely proportional to d .
 B It is directly proportional to l and inversely proportional to d^2 .
 C It is inversely proportional to l and directly proportional to d .
 D It is inversely proportional to l and directly proportional to d^2 .

- 33 A student sets up a circuit. The circuit diagram shows how the positive and negative terminals of a voltmeter are connected to the circuit. The voltmeter has an initial reading that is positive.

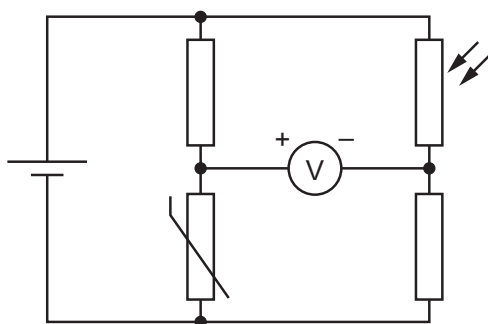

Which changes, if any, in temperature and light intensity would cause the voltmeter reading to **decrease**?

	temperature	light intensity
A	increase	increase
B	no change	decrease
C	decrease	no change
D	decrease	decrease

- 34 Some resistors and a battery of electromotive force (e.m.f.) E and negligible internal resistance are connected in series, as shown.

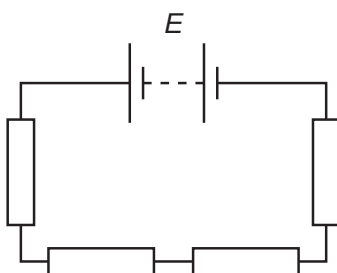

Which statement is correct?

- A** The e.m.f. across each resistor equals the potential difference across the battery.
- B** The potential difference across each resistor equals the e.m.f. E of the battery.
- C** The sum of the e.m.f.s across the resistors equals the potential difference across the battery.
- D** The sum of the potential differences across the resistors equals the e.m.f. E of the battery.

- 35 Kirchhoff's first law is a consequence of the conservation of which physical quantity?
- A charge
 B energy
 C linear momentum
 D potential difference

- 36 The diagram shows a network of resistors. Each resistor has a resistance of $6.0\ \Omega$.

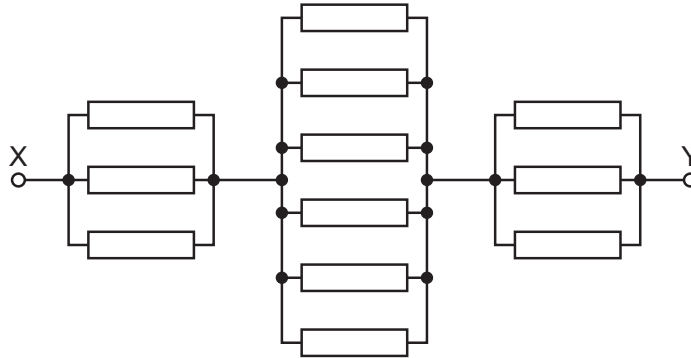

What is the total resistance of the network between points X and Y?

- A $3.0\ \Omega$ B $5.0\ \Omega$ C $7.2\ \Omega$ D $18\ \Omega$
- 37 In the circuit shown, a battery of negligible internal resistance is connected in series with a pair of fixed resistors R_1 and R_2 .

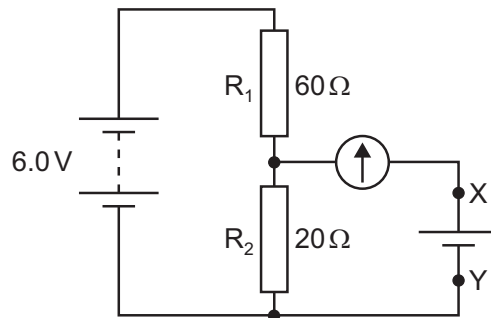

The circuit is to be used to test whether the electromotive force (e.m.f.) of a particular cell is $1.5\ \text{V}$. The cell is connected between terminals X and Y in parallel with R_2 and in series with a galvanometer.

Which statement about the test is correct?

- A Any non-zero reading on the galvanometer means the cell has an e.m.f. of $1.5\ \text{V}$.
 B The battery does not need to have an e.m.f. of $6.0\ \text{V}$.
 C The cell may be connected either way round between X and Y.
 D The galvanometer does not need a scale calibrated in amperes.

- 38 Two nuclides are different isotopes of the same element.

Which statement about the nuclides is correct?

- A Neutral atoms of the nuclides have the same number of electrons.
- B Nuclei of the nuclides have different numbers of protons.
- C Nuclei of the nuclides have the same number of nucleons.
- D Nuclei of the nuclides have the same number of neutrons.

- 39 The charge-to-mass ratio r of a particle is given by the equation shown.

$$r = \frac{\text{charge on particle}}{\text{mass of particle}}$$

The value of r is determined for an α -particle, a β^+ particle and a proton p .

Which list shows the particles in order of increasing magnitude of r from left to right?

- A $\alpha \rightarrow \beta^+ \rightarrow p$
- B $\alpha \rightarrow p \rightarrow \beta^+$
- C $p \rightarrow \alpha \rightarrow \beta^+$
- D $p \rightarrow \beta^+ \rightarrow \alpha$

- 40 Which combination of up (u) and down (d) quarks forms a neutron?

- A u u u B u u d C u d d D d d d

BLANK PAGE

Permission to reproduce items where third-party owned material protected by copyright is included has been sought and cleared where possible. Every reasonable effort has been made by the publisher (UCLES) to trace copyright holders, but if any items requiring clearance have unwittingly been included, the publisher will be pleased to make amends at the earliest possible opportunity.

To avoid the issue of disclosure of answer-related information to candidates, all copyright acknowledgements are reproduced online in the Cambridge Assessment International Education Copyright Acknowledgements Booklet. This is produced for each series of examinations and is freely available to download at www.cambridgeinternational.org after the live examination series.

Cambridge Assessment International Education is part of Cambridge Assessment. Cambridge Assessment is the brand name of the University of Cambridge Local Examinations Syndicate (UCLES), which is a department of the University of Cambridge.