



# Cambridge International AS & A Level

CANDIDATE NAME



CENTRE NUMBER

--	--	--	--	--

CANDIDATE NUMBER

--	--	--	--

## PHYSICS

9702/22

Paper 2 AS Level Structured Questions

October/November 2025

1 hour 15 minutes

You must answer on the question paper.

No additional materials are needed.

### INSTRUCTIONS

- Answer **all** questions.
- Use a black or dark blue pen. You may use an HB pencil for any diagrams or graphs.
- Write your name, centre number and candidate number in the boxes at the top of the page.
- Write your answer to each question in the space provided.
- Do **not** use an erasable pen or correction fluid.
- Do **not** write on any bar codes.
- You may use a calculator.
- You should show all your working and use appropriate units.

### INFORMATION

- The total mark for this paper is 60.
- The number of marks for each question or part question is shown in brackets [ ].

This document has **16** pages. Any blank pages are indicated.



### Data

acceleration of free fall	$g = 9.81 \text{ m s}^{-2}$
speed of light in free space	$c = 3.00 \times 10^8 \text{ m s}^{-1}$
elementary charge	$e = 1.60 \times 10^{-19} \text{ C}$
unified atomic mass unit	$1 \text{ u} = 1.66 \times 10^{-27} \text{ kg}$
rest mass of proton	$m_p = 1.67 \times 10^{-27} \text{ kg}$
rest mass of electron	$m_e = 9.11 \times 10^{-31} \text{ kg}$
Avogadro constant	$N_A = 6.02 \times 10^{23} \text{ mol}^{-1}$
molar gas constant	$R = 8.31 \text{ J K}^{-1} \text{ mol}^{-1}$
Boltzmann constant	$k = 1.38 \times 10^{-23} \text{ J K}^{-1}$
gravitational constant	$G = 6.67 \times 10^{-11} \text{ N m}^2 \text{ kg}^{-2}$
permittivity of free space	$\epsilon_0 = 8.85 \times 10^{-12} \text{ F m}^{-1}$ $\left(\frac{1}{4\pi\epsilon_0}\right) = 8.99 \times 10^9 \text{ m F}^{-1}$
Planck constant	$h = 6.63 \times 10^{-34} \text{ J s}$
Stefan–Boltzmann constant	$\sigma = 5.67 \times 10^{-8} \text{ W m}^{-2} \text{ K}^{-4}$

### Formulae

uniformly accelerated motion	$s = ut + \frac{1}{2}at^2$ $v^2 = u^2 + 2as$
hydrostatic pressure	$\Delta p = \rho g \Delta h$
upthrust	$F = \rho g V$
Doppler effect for sound waves	$f_o = \frac{f_s v}{v \pm v_s}$
electric current	$I = Anvq$
resistors in series	$R = R_1 + R_2 + \dots$
resistors in parallel	$\frac{1}{R} = \frac{1}{R_1} + \frac{1}{R_2} + \dots$



DO NOT WRITE IN THIS MARGIN

\* 0000800000003 \*

DFD



3

BLANK PAGE





- 1 Scientists are investigating the variation in air pressure at different locations on a mountain.
- (a) The scientists take measurements of several physical quantities at each location.

Complete Table 1.1 by stating the SI base unit for each quantity and identifying with a tick (✓) whether each quantity is a scalar or a vector. Use the space for any working.

**Table 1.1**

quantity measured	SI base unit	scalar	vector
air temperature			
air pressure			

[2]

- (b) (i) At one location, the density of the air is  $1.1 \text{ kg m}^{-3}$ . A spherical weather balloon is filled with a gas and released from rest. The balloon has radius 0.90 m.

Calculate the upthrust acting on the balloon when it is released.

upthrust = ..... N [2]

- (ii) Explain why an upthrust acts on the balloon.

.....  
 .....  
 .....  
 ..... [2]

DO NOT WRITE IN THIS MARGIN





(iii) The balloon has weight 19 N.

Calculate the magnitude of the initial acceleration of the balloon.

acceleration = .....  $\text{ms}^{-2}$  [3]

(c) A quantity  $c$  relating to the motion of the balloon is calculated from three measured quantities  $k$ ,  $F$  and  $v$  using the formula

$$c = \frac{2kF}{v^2}.$$

The percentage uncertainties in the measured quantities are given in Table 1.2.

**Table 1.2**

measured quantity	percentage uncertainty
$k$	5%
$F$	3%
$v$	4%

The calculated value of  $c$  is 1.8.

Determine the absolute uncertainty in  $c$ .

absolute uncertainty = ..... [2]

[Total: 11]



- 2 A spacecraft in deep space uses jets of hot gas from its thrusters to change its velocity. Fig. 2.1 shows a side view of the spacecraft and some of its thrusters.

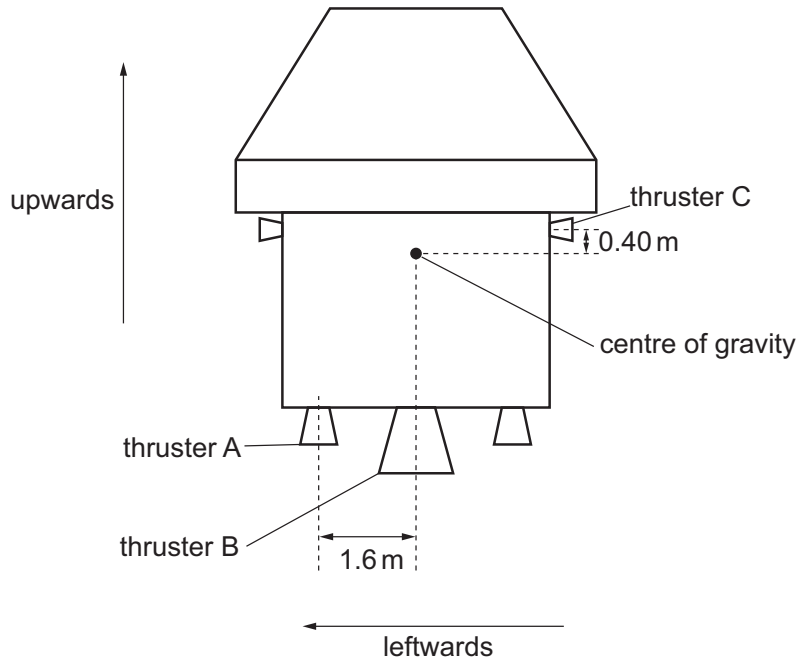

Fig. 2.1 (not to scale)

Thruster A is a distance of 1.6 m leftwards from the centre of gravity of the spacecraft. Thruster C is a distance of 0.40 m upwards from the centre of gravity of the spacecraft.

Thrusters A and B can produce forces on the spacecraft in the upwards direction only. Thruster C can produce a force on the spacecraft in the leftwards direction only. All the thrusters shown produce forces entirely in the same plane as the centre of gravity.

- (a) (i) Thruster A is activated, producing a force of 60 N upwards on the spacecraft. Thruster C is also activated, producing a force of 220 N in the leftwards direction on the spacecraft.

Calculate the resultant moment due to these forces about the centre of gravity.

resultant moment = ..... N m [2]

- (ii) State and explain whether the forces from A and C are a couple.

.....

.....

..... [1]



- (b) Thrusters A and C are now switched off and the spacecraft is stationary. Thruster B is activated at time  $t_1$ , producing a constant force on the spacecraft until the fuel runs out at time  $t_2$ . As the fuel is used, the total mass of the spacecraft decreases.

On Fig. 2.2, sketch the variation of speed of the spacecraft with time from  $t_1$  to  $t_2$ .

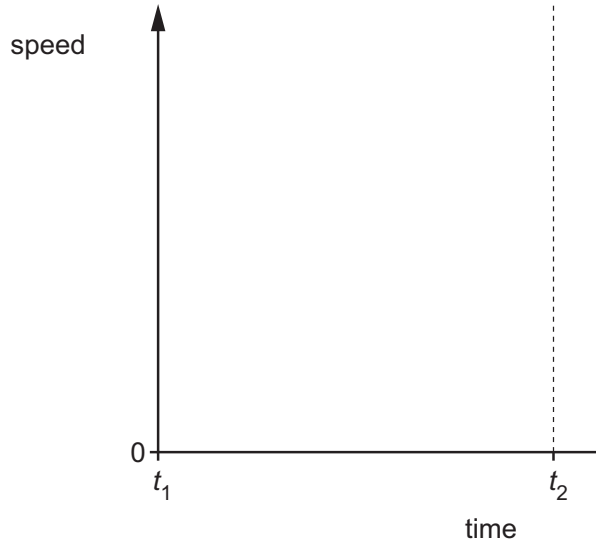

Fig. 2.2

[2]

DO NOT WRITE IN THIS MARGIN

DO NOT WRITE IN THIS MARGIN

DO NOT WRITE IN THIS MARGIN

DO NOT WRITE IN THIS MARGIN

DO NOT WRITE IN THIS MARGIN





(c) The spacecraft now splits apart into a carrier and a payload as shown in Fig. 2.3.

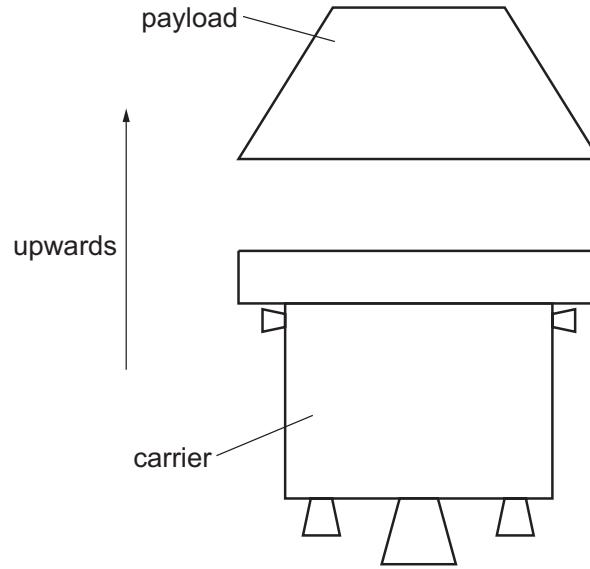

Fig. 2.3

During the split, an average force of 5500 N acts on the payload for a time of 0.36 s. The velocity of the payload increases by  $8.5 \text{ m s}^{-1}$  in the upwards direction.

The combined mass of the carrier and payload is  $2.5 \times 10^3 \text{ kg}$ .

(i) State the principle of conservation of momentum.

.....

.....

..... [2]

(ii) Show that the mass of the payload is 230 kg.

[2]



DO NOT WRITE IN THIS MARGIN

DO NOT WRITE IN THIS MARGIN

DO NOT WRITE IN THIS MARGIN

DO NOT WRITE IN THIS MARGIN

DO NOT WRITE IN THIS MARGIN

\* 0000800000009 \*

DFD



9

(iii) Calculate the magnitude of the change in velocity of the carrier.

change in velocity = .....  $\text{ms}^{-1}$  [3]

[Total: 12]



- 3 A spring is fixed at one end and attached to the frame of a pulley at the other end. A cable is passed around the wheel of the pulley. The spring is stretched to a fixed length using the cable and pulley.

Fig. 3.1 shows the view from above of the spring, cable and pulley.

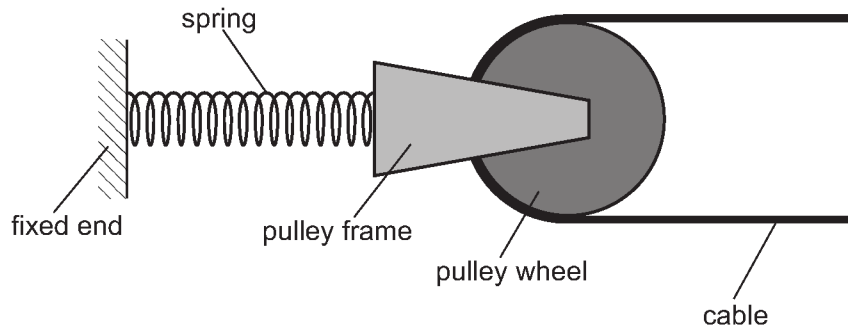

Fig. 3.1

The spring obeys Hooke's law and has a spring constant  $k$  of  $250 \text{ N m}^{-1}$ . A force  $F$  acts on the spring. The tension in the cable is  $T$ . The pulley is in equilibrium.

- (a) On Fig. 3.2, draw labelled arrows to show the directions of the forces acting on the pulley.

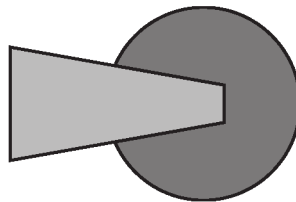

Fig. 3.2

[2]

- (b) The force  $F$  is 110N.

- (i) Determine  $T$ .

$T = \dots\dots\dots \text{ N [1]}$





- (ii) Calculate the extension of the spring.

extension = ..... m [2]

- (c) A second identical spring with the same spring constant of  $250 \text{ N m}^{-1}$  is now also connected to the pulley, as shown in Fig. 3.3.

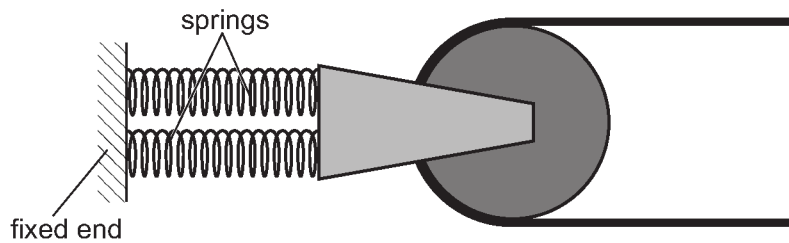

Fig. 3.3

The tension in the cable is kept the same. The pulley is again in equilibrium.

- (i) Determine the extension of the springs.

extension = ..... m [2]

- (ii) The elastic potential energy stored in the spring in Fig. 3.1 is  $E_1$ . The **total** elastic potential energy stored in the two springs in Fig. 3.3 is  $E_2$ .

Calculate the ratio  $\frac{E_1}{E_2}$ .

ratio = ..... [2]

[Total: 9]



- 4 A laser emits visible light of a single frequency in a vacuum. The light is incident normally on a double slit and then forms a pattern of bright and dark fringes on a screen, as shown in Fig. 4.1.

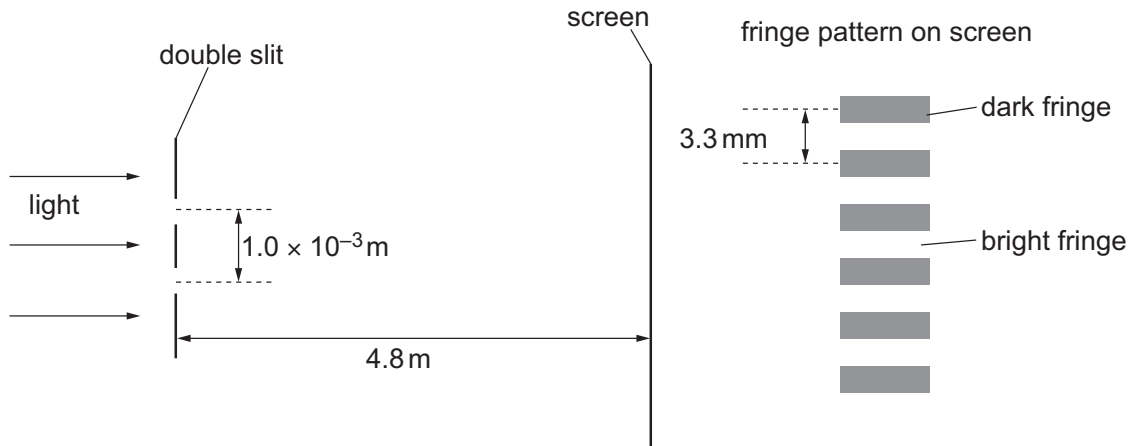

Fig. 4.1 (not to scale)

The separation of the slits is  $1.0 \times 10^{-3} \text{ m}$ . The distance from the slits to the screen is  $4.8 \text{ m}$ . The distance between the centres of adjacent dark fringes on the screen is  $3.3 \text{ mm}$ .

- (a) Explain how the pattern of bright and dark fringes is formed.

.....

.....

.....

.....

.....

..... [3]

- (b) Calculate the frequency of the light emitted by the laser.

frequency = ..... Hz [4]





- (c) The double slit is removed. A second laser is placed beside the first laser. The second laser produces visible light of a different frequency from that of the first laser. The beams of light from the two lasers overlap on the screen.

Explain why a steady pattern of bright and dark fringes is **not** formed on the screen.

.....

..... [1]

[Total: 8]



- 5 Fig. 5.1 shows a circuit containing a battery, two fixed resistors X and Y, and a light-dependent resistor (LDR) Z.

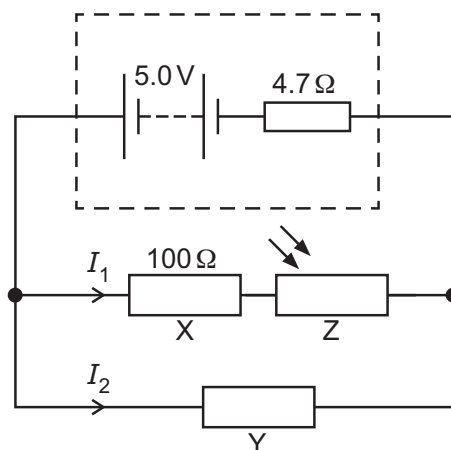

Fig. 5.1

The battery has electromotive force (e.m.f.) 5.0V and internal resistance  $4.7\Omega$ . The current in X is  $I_1$  and the current in Y is  $I_2$ .

The resistance of X is  $100\Omega$ . The resistance of Z varies with the intensity of light incident on it as shown in Fig. 5.2.

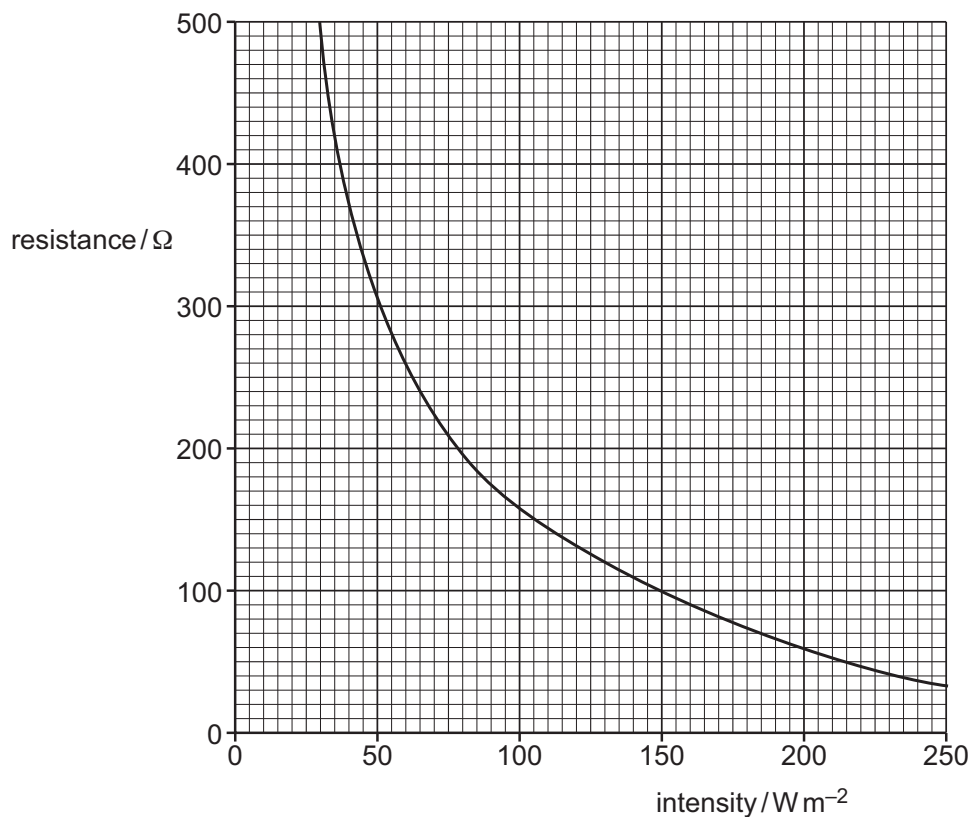

Fig. 5.2





(a) State Kirchhoff's first law.

.....  
..... [1]

(b) The intensity of light incident on Z is  $130 \text{ W m}^{-2}$ . The current in the battery is 38 mA.

(i) Show that the terminal potential difference of the battery is 4.8 V.

[2]

(ii) Calculate the current  $I_2$  in Y.

$I_2 = \dots\dots\dots \text{ A}$  [3]

(iii) Calculate the power dissipated in Y.

power =  $\dots\dots\dots \text{ W}$  [2]

(iv) The intensity of the light incident on Z decreases.

State and explain the effect on the terminal potential difference of the battery.

.....  
.....  
.....  
.....  
..... [3]

[Total: 11]





6 (a) State what is meant by a fundamental particle.

.....  
..... [1]

(b) (i) Particle Q is a meson with a charge of 0.

Determine a possible quark composition for Q.

..... [2]

(ii) Particle Q has a mass of 0.67 u and a kinetic energy of  $2.1 \times 10^{-16}$  J.

Calculate the speed of particle Q.

speed = .....  $\text{ms}^{-1}$  [3]

(c) Radium-228 ( $^{228}_{88}\text{Ra}$ ) is a radioactive nuclide.

(i) State the number of electrons in a neutral atom of radium-228.

number of electrons = ..... [1]

(ii) A nucleus of radium-228 undergoes a series of decays to form nucleus X.  
During the process, 5  $\alpha$ -particles and 4  $\beta^-$  particles are emitted.

Determine the number of protons and the number of neutrons in nucleus X.

number of protons = .....

number of neutrons = .....

[2]

[Total: 9]

To avoid the issue of disclosure of answer-related information to candidates, all copyright acknowledgements are reproduced online in the Cambridge Assessment International Education Copyright Acknowledgements Booklet. This is produced for each series of examinations and is freely available to download at [www.cambridgeinternational.org](http://www.cambridgeinternational.org) after the live examination series.

