

Cambridge International AS & A Level

CANDIDATE
NAME

CENTRE
NUMBER

--	--	--	--	--

CANDIDATE
NUMBER

--	--	--	--

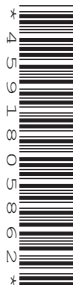

PHYSICS

9702/42

Paper 4 A Level Structured Questions

May/June 2022

2 hours

You must answer on the question paper.

No additional materials are needed.

INSTRUCTIONS

- Answer **all** questions.
- Use a black or dark blue pen. You may use an HB pencil for any diagrams or graphs.
- Write your name, centre number and candidate number in the boxes at the top of the page.
- Write your answer to each question in the space provided.
- Do **not** use an erasable pen or correction fluid.
- Do **not** write on any bar codes.
- You may use a calculator.
- You should show all your working and use appropriate units.

INFORMATION

- The total mark for this paper is 100.
- The number of marks for each question or part question is shown in brackets [].

This document has **24** pages. Any blank pages are indicated.

Data

acceleration of free fall	$g = 9.81 \text{ m s}^{-2}$
speed of light in free space	$c = 3.00 \times 10^8 \text{ m s}^{-1}$
elementary charge	$e = 1.60 \times 10^{-19} \text{ C}$
unified atomic mass unit	$1 \text{ u} = 1.66 \times 10^{-27} \text{ kg}$
rest mass of proton	$m_p = 1.67 \times 10^{-27} \text{ kg}$
rest mass of electron	$m_e = 9.11 \times 10^{-31} \text{ kg}$
Avogadro constant	$N_A = 6.02 \times 10^{23} \text{ mol}^{-1}$
molar gas constant	$R = 8.31 \text{ J K}^{-1} \text{ mol}^{-1}$
Boltzmann constant	$k = 1.38 \times 10^{-23} \text{ J K}^{-1}$
gravitational constant	$G = 6.67 \times 10^{-11} \text{ N m}^2 \text{ kg}^{-2}$
permittivity of free space	$\epsilon_0 = 8.85 \times 10^{-12} \text{ F m}^{-1}$ $(\frac{1}{4\pi\epsilon_0} = 8.99 \times 10^9 \text{ m F}^{-1})$
Planck constant	$h = 6.63 \times 10^{-34} \text{ J s}$
Stefan–Boltzmann constant	$\sigma = 5.67 \times 10^{-8} \text{ W m}^{-2} \text{ K}^{-4}$

Formulae

uniformly accelerated motion	$s = ut + \frac{1}{2}at^2$ $v^2 = u^2 + 2as$
hydrostatic pressure	$\Delta p = \rho g \Delta h$
upthrust	$F = \rho g V$
Doppler effect for sound waves	$f_o = \frac{f_s v}{v \pm v_s}$
electric current	$I = Anvq$
resistors in series	$R = R_1 + R_2 + \dots$
resistors in parallel	$\frac{1}{R} = \frac{1}{R_1} + \frac{1}{R_2} + \dots$

gravitational potential	$\phi = -\frac{GM}{r}$
gravitational potential energy	$E_P = -\frac{GMm}{r}$
pressure of an ideal gas	$p = \frac{1}{3} \frac{Nm}{V} \langle c^2 \rangle$
simple harmonic motion	$a = -\omega^2 x$
velocity of particle in s.h.m.	$v = v_0 \cos \omega t$ $v = \pm \omega \sqrt{(x_0^2 - x^2)}$
electric potential	$V = \frac{Q}{4\pi\epsilon_0 r}$
electrical potential energy	$E_P = \frac{Qq}{4\pi\epsilon_0 r}$
capacitors in series	$\frac{1}{C} = \frac{1}{C_1} + \frac{1}{C_2} + \dots$
capacitors in parallel	$C = C_1 + C_2 + \dots$
discharge of a capacitor	$x = x_0 e^{-\frac{t}{RC}}$
Hall voltage	$V_H = \frac{BI}{ntq}$
alternating current/voltage	$x = x_0 \sin \omega t$
radioactive decay	$x = x_0 e^{-\lambda t}$
decay constant	$\lambda = \frac{0.693}{t_{\frac{1}{2}}}$
intensity reflection coefficient	$\frac{I_R}{I_0} = \frac{(Z_1 - Z_2)^2}{(Z_1 + Z_2)^2}$
Stefan–Boltzmann law	$L = 4\pi\sigma r^2 T^4$
Doppler redshift	$\frac{\Delta\lambda}{\lambda} \approx \frac{\Delta f}{f} \approx \frac{v}{c}$

- 1 (a) (i) Define gravitational potential at a point.

.....

 [2]

- (ii) Starting from the equation for the gravitational potential due to a point mass, show that the gravitational potential energy E_p of a point mass m at a distance r from another point mass M is given by

$$E_p = -\frac{GMm}{r}$$

where G is the gravitational constant.

[1]

- (b) Fig. 1.1 shows the path of a comet of mass 2.20×10^{14} kg as it passes around a star of mass 1.99×10^{30} kg.

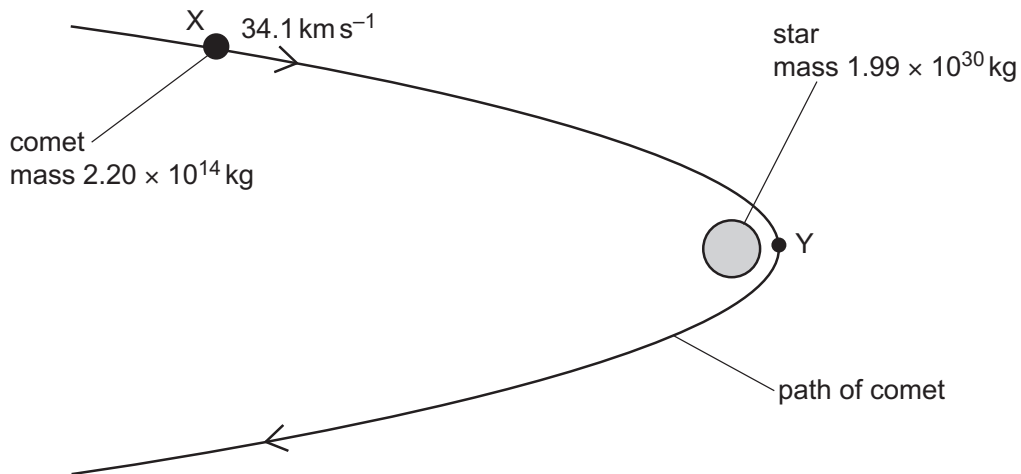

Fig. 1.1 (not to scale)

At point X, the comet is 8.44×10^{11} m from the centre of the star and is moving at a speed of 34.1 km s^{-1} .

At point Y, the comet passes its point of closest approach to the star. At this point, the comet is a distance of 6.38×10^{10} m from the centre of the star.

Both the comet and the star can be considered as point masses at their centres.

- (i) Calculate the magnitude of the change in the gravitational potential energy ΔE_p of the comet as it moves from position X to position Y.

$$\Delta E_p = \dots\dots\dots \text{ J [2]}$$

- (ii) State, with a reason, whether the change in gravitational potential energy in (b)(i) is an increase or a decrease.

.....
 [1]

- (iii) Use your answer in (b)(i) to determine the speed, in km s^{-1} , of the comet at point Y.

$$\text{speed} = \dots\dots\dots \text{ km s}^{-1} [3]$$

- (c) A second comet passes point X with the same speed as the comet in (b) and travelling in the same direction. This comet is gradually losing mass. The mass of this comet when it passes point X is the same as the mass of the comet in (b).

Suggest, with a reason, how the path of the second comet compares with the path shown in Fig. 1.1.

.....
 [1]

[Total: 10]

- 2 (a) State Coulomb's law.

.....

 [2]

- (b) Positronium is a system in which an electron and a positron orbit, with the same period, around their common centre of mass, as shown in Fig. 2.1.

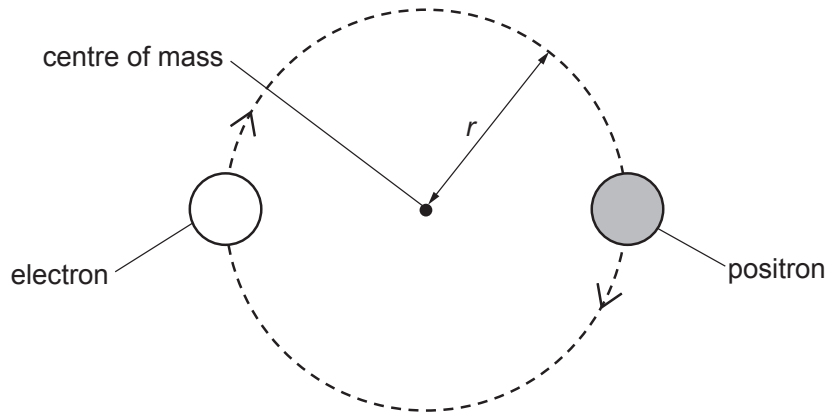

Fig. 2.1 (not to scale)

The radius r of the orbit of both particles is 1.59×10^{-10} m.

- (i) Explain how the electric force between the electron and the positron causes the path of the moving particles to be circular.

.....

 [2]

- (ii) Show that the magnitude of the electric force between the electron and the positron is 2.28×10^{-9} N.

[2]

- (iii) Use the information in (b)(ii) to determine the period of the circular orbit of the two particles.

period = s [3]

- (c) Positronium is highly unstable, and after a very short period of time it becomes gamma radiation.

- (i) Describe how gamma radiation is formed from the two particles in positronium.

.....
.....
.....
..... [3]

- (ii) State **one** medical application of the process described in (c)(i).

..... [1]

[Total: 13]

- 3 (a) Define specific latent heat of vaporisation.

.....

 [2]

- (b) The specific latent heat of vaporisation of water at atmospheric pressure of 1.0×10^5 Pa is $2.3 \times 10^6 \text{ J kg}^{-1}$. A mass of 0.37 kg of liquid water at 100°C is provided with the thermal energy needed to vaporise all of the water at atmospheric pressure.

- (i) Calculate the thermal energy q supplied to the water.

$$q = \dots\dots\dots \text{ J [1]}$$

- (ii) The mass of 1.0 mol of water is 18g. Assume that water vapour can be considered to behave as an ideal gas.

Show that the volume of water vapour produced is 0.64 m^3 .

[3]

- (iii) Assume that the initial volume of the liquid water is negligible compared with the volume of water vapour produced.

Determine the magnitude of the work done by the water in expanding against the atmosphere when it vaporises.

$$\text{work done} = \dots\dots\dots \text{ J [2]}$$

- (iv) Use your answers in (b)(i) and (b)(iii) to determine the increase in internal energy of the water when it vaporises at 100 °C. Explain your reasoning.

increase in internal energy = J [2]

- (c) Use the first law of thermodynamics to suggest, with a reason, how the specific latent heat of vaporisation of water at a pressure greater than atmospheric pressure compares with its value at atmospheric pressure.

.....
.....
..... [2]

[Total: 12]

- 4 (a) State what is meant by resonance.

.....

.....

..... [2]

- (b) Fig. 4.1 shows a heavy pendulum and a light pendulum, both suspended from the same piece of string. This string is secured at each end to fixed points.

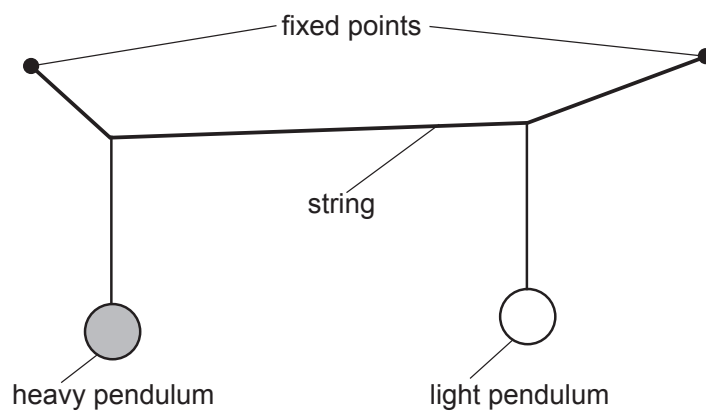

Fig. 4.1

Both pendulums have the same natural frequency. The heavy pendulum is set oscillating perpendicular to the plane of the diagram. As it oscillates, it causes the light pendulum to oscillate.

Fig. 4.2 shows the variation with time t of the displacements of the two pendulums for three oscillations.

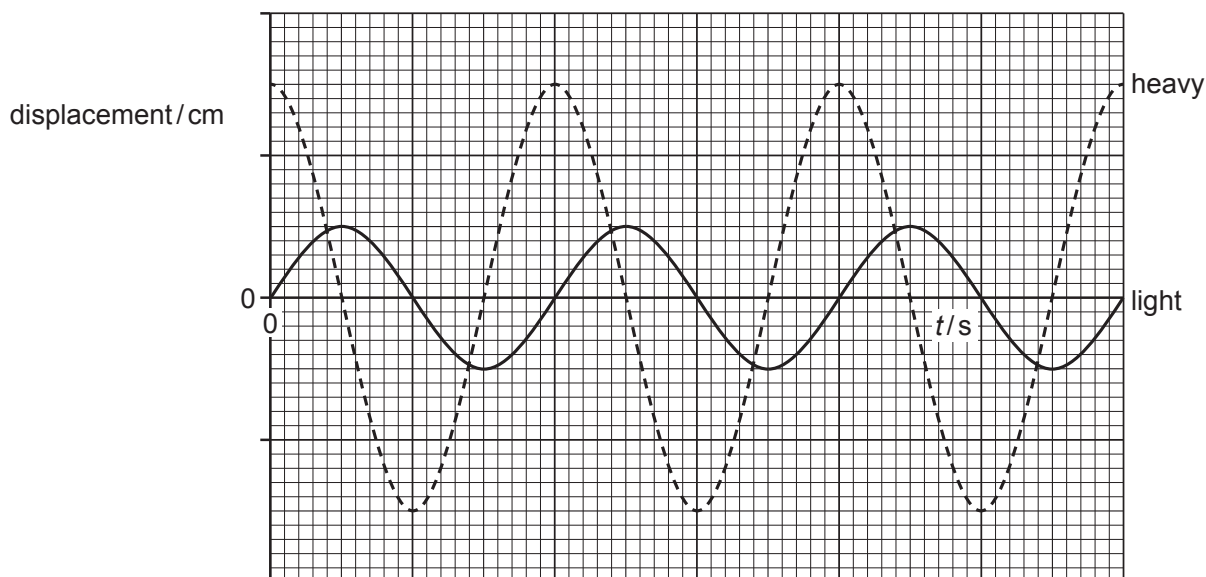

Fig. 4.2

The variation with t of the displacement x of the light pendulum is given by

$$x = 0.25 \sin 5.0\pi t$$

where x is in centimetres and t is in seconds.

- (i) Calculate the period T of the oscillations.

$$T = \dots\dots\dots \text{ s [2]}$$

- (ii) On Fig. 4.2, label both of the axes with the correct scales. Use the space below for any additional working that you need.

[2]

- (iii) Determine the magnitude of the phase difference ϕ between the oscillations of the light and heavy pendulums. Give a unit with your answer.

$$\phi = \dots\dots\dots \text{ unit } \dots\dots\dots [2]$$

[Total: 8]

- 5 (a) Define the capacitance of a parallel plate capacitor.

.....

.....

..... [2]

- (b) Two capacitors, of capacitances C_1 and C_2 , are connected in parallel to a power supply of electromotive force (e.m.f.) E , as shown in Fig. 5.1.

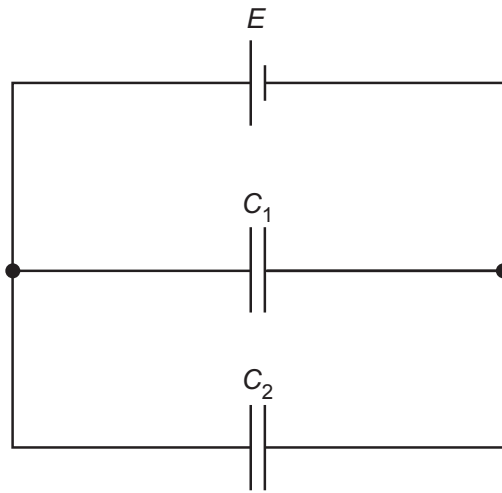

Fig. 5.1

Show that the combined capacitance C_T of the two capacitors is given by

$$C_T = C_1 + C_2.$$

Explain your reasoning. You may draw on Fig. 5.1 if you wish.

[3]

- (c) Two capacitors of capacitances $22\ \mu\text{F}$ and $47\ \mu\text{F}$, and a resistor of resistance $2.7\ \text{M}\Omega$, are connected into the circuit of Fig. 5.2.

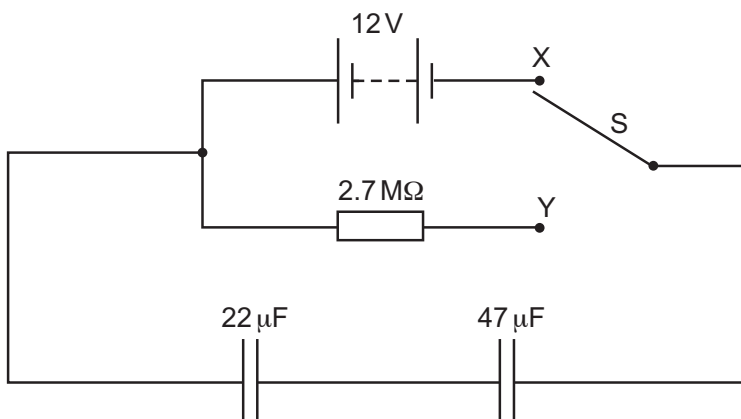

Fig. 5.2

The battery has an e.m.f. of 12V.

- (i) Show that the combined capacitance of the two capacitors is $15\ \mu\text{F}$.

[1]

- (ii) The two-way switch S is initially at position X, so that the capacitors are fully charged. Use the information in (c)(i) to calculate the total energy stored in the two capacitors.

total energy = J [2]

- (iii) The two-way switch is now moved to position Y.

Determine the time taken for the potential difference (p.d.) across the $22\ \mu\text{F}$ capacitor to become 6.0V.

time = s [3]

[Total: 11]

[Turn over

- 6 (a) State the **two** conditions that must be satisfied for a copper wire, placed in a magnetic field, to experience a magnetic force.

1

.....

2

.....

[2]

- (b) A long air-cored solenoid is connected to a power supply, so that the solenoid creates a magnetic field. Fig. 6.1 shows a cross-section through the middle of the solenoid.

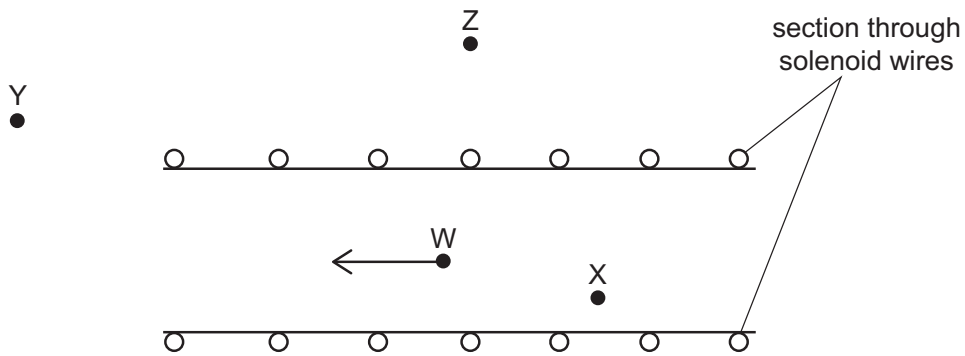

Fig. 6.1

The direction of the magnetic field at point W is indicated by the arrow. Three other points are labelled X, Y and Z.

- (i) On Fig. 6.1, draw arrows to indicate the direction of the magnetic field at each of the points X, Y and Z. [3]

- (ii) Compare the magnitude of the flux density of the magnetic field:

• at X and at W

.....

• at Y and at Z.

.....

[2]

(c) Two long parallel current-carrying wires are placed near to each other in a vacuum.

Explain why these wires exert a magnetic force on each other. You may draw a labelled diagram if you wish.

.....

.....

.....

..... [3]

[Total: 10]

- 7 (a) State Faraday's law of electromagnetic induction.

.....

.....

..... [2]

- (b) Two coils are wound on an iron bar, as shown in Fig. 7.1.

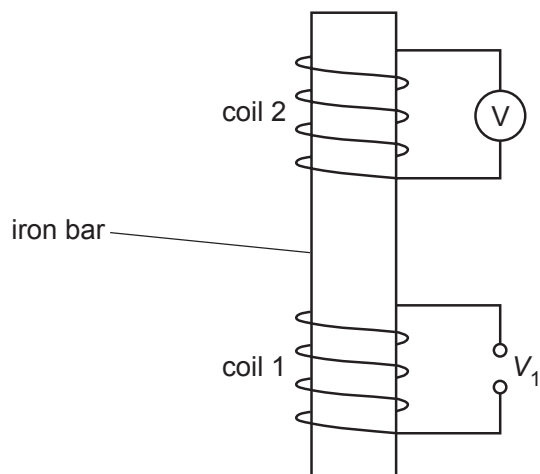

Fig. 7.1

Coil 1 is connected to a potential difference (p.d.) V_1 that gives rise to a magnetic field in the iron bar.

Fig. 7.2 shows the variation with time t of the magnetic flux density B in the iron bar.

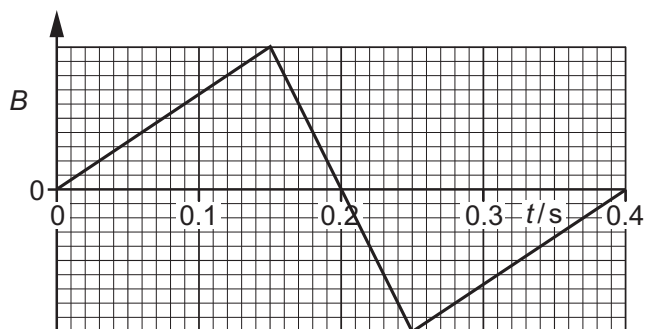

Fig. 7.2

A voltmeter measures the electromotive force (e.m.f.) V_2 that is induced across coil 2.

On Fig. 7.3, sketch the variation with t of V_2 between $t = 0$ and $t = 0.40$ s.

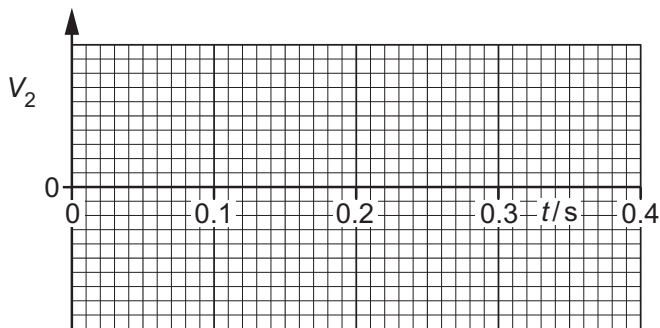

Fig. 7.3

[4]

- (c) Coil 2 in (b) is now replaced with a copper ring that rests loosely on top of coil 1. The supply to coil 1 is replaced with a cell and a switch that is initially open, as shown in Fig. 7.4.

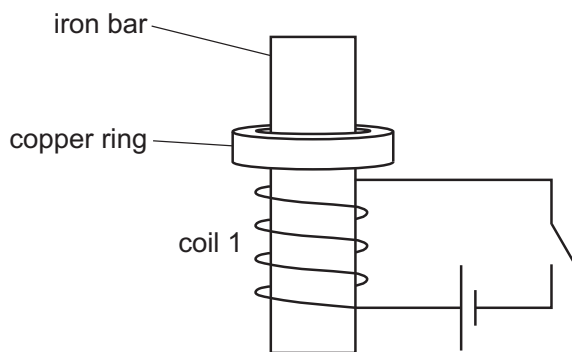

Fig. 7.4

- (i) The switch is now closed. As it is closed, the copper ring is observed to jump upwards.
Explain why this happens.

.....

 [3]

- (ii) Suggest, with a reason, what would be the effect of repeating the procedure in (c)(i) with the terminals of the cell reversed.

.....
 [1]

[Total: 10]

8 (a) State **one** piece of experimental evidence for:

(i) the particulate nature of electromagnetic radiation

..... [1]

(ii) the wave nature of matter.

..... [1]

(b) (i) Calculate the de Broglie wavelength λ of an alpha-particle moving at a speed of $6.2 \times 10^7 \text{ m s}^{-1}$.

$\lambda =$ m [3]

(ii) The speed v of the alpha-particle in (b)(i) is gradually reduced to zero.

On Fig. 8.1, sketch the variation with v of λ .

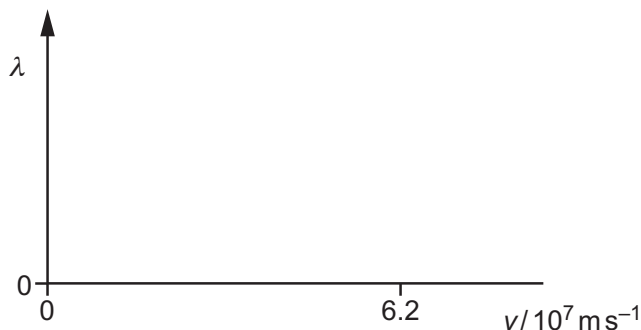

Fig. 8.1

[2]

(c) Suggest an explanation for why people are not observed to diffract when they walk through a doorway.

.....

 [1]

[Total: 8]

9 (a) (i) State Hubble's law.

.....
.....
..... [2]

(ii) Explain how cosmologists use observations of emission spectra from stars in distant galaxies to determine that the Universe is expanding.

.....
.....
.....
..... [2]

(b) Explain how Hubble's law and the idea of the expanding Universe lead to the Big Bang theory of the origin of the Universe.

.....
.....
.....
..... [3]

[Total: 7]

- 10 (a) State what is meant by radioactive decay.

.....

.....

..... [2]

- (b) A radioactive sample consists of an isotope X of half-life T that decays to form a stable product. Only X and the stable product are present in the sample.

At time $t = 0$, the sample has an activity of A_0 and contains N_0 nuclei of X.

- (i) On Fig. 10.1, sketch the variation with t of the number N of nuclei of X present in the sample. Your line should extend from time $t = 0$ to time $t = 3T$.

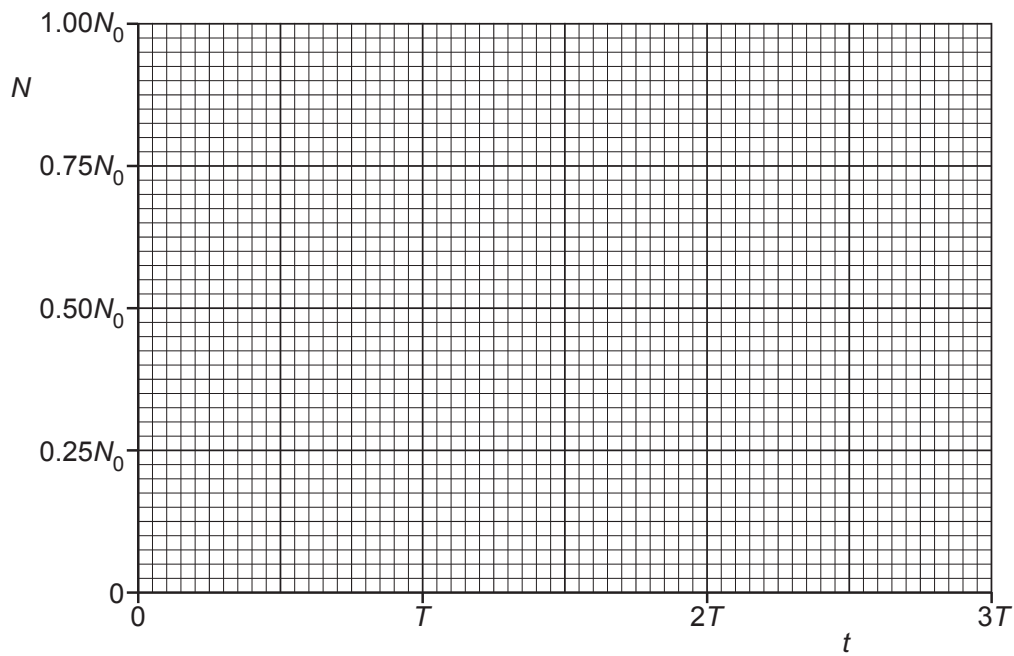

Fig. 10.1

[3]

- (ii) On Fig. 10.2, sketch the variation with N of the activity A of the sample for values of N between $N = 0$ and $N = N_0$.

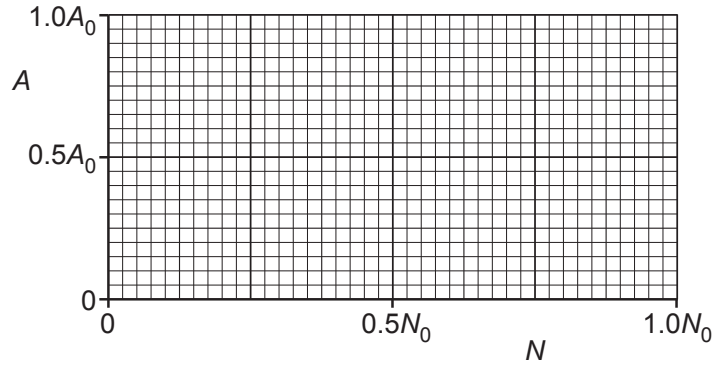

Fig. 10.2

[2]

- (c) State the name of the quantity represented by the gradient of your line in:

- (i) Fig. 10.1

..... [1]

- (ii) Fig. 10.2.

..... [1]

- (d) For the sample in (b), calculate the fraction $\frac{N}{N_0}$ at time $t = 1.70T$.

$\frac{N}{N_0} = \dots\dots\dots$ [2]

[Total: 11]

BLANK PAGE

Permission to reproduce items where third-party owned material protected by copyright is included has been sought and cleared where possible. Every reasonable effort has been made by the publisher (UCLES) to trace copyright holders, but if any items requiring clearance have unwittingly been included, the publisher will be pleased to make amends at the earliest possible opportunity.

To avoid the issue of disclosure of answer-related information to candidates, all copyright acknowledgements are reproduced online in the Cambridge Assessment International Education Copyright Acknowledgements Booklet. This is produced for each series of examinations and is freely available to download at www.cambridgeinternational.org after the live examination series.

Cambridge Assessment International Education is part of Cambridge Assessment. Cambridge Assessment is the brand name of the University of Cambridge Local Examinations Syndicate (UCLES), which is a department of the University of Cambridge.