

- 1 A student is investigating the acceleration of a trolley moving up an inclined plane as shown in Fig. 1.1.

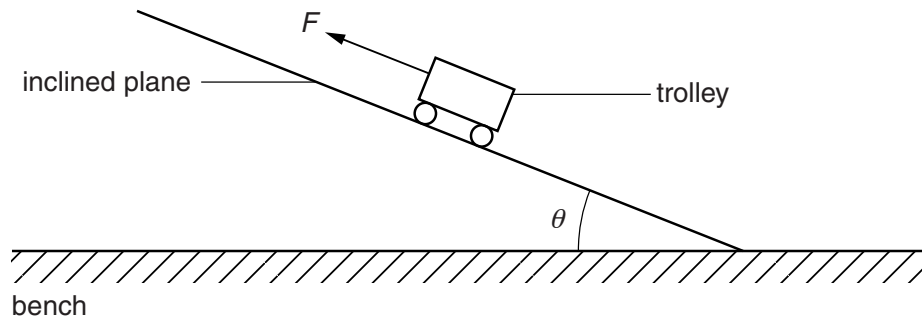

Fig. 1.1

The student is investigating the relationship between the acceleration a of the trolley and the angle θ of the inclined plane when a force F is applied to the trolley.

It is suggested that the relationship is

$$ma = F - (mg \sin \theta + k)$$

where g is the acceleration of free fall, m is the mass of the trolley and k is a constant.

Design a laboratory experiment to test the relationship between a and θ . Explain how your results could be used to determine a value for k . You should draw a diagram, on page 3, showing the arrangement of your equipment. In your account you should pay particular attention to

- the procedure to be followed,
- the measurements to be taken,
- the control of variables,
- the analysis of the data,
- any safety precautions to be taken.

[15]

- 2 A student is investigating how the resistance of a wire depends on the diameter of the wire.

The circuit is set up as shown in Fig. 2.1.

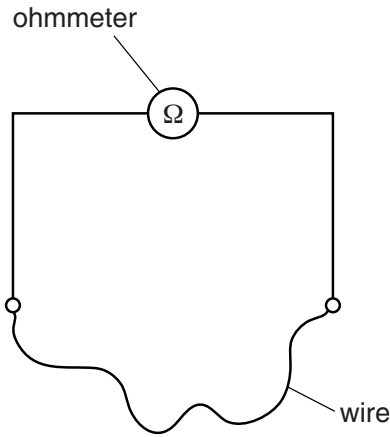

Fig. 2.1

The resistance R of the wire is measured using an ohmmeter.

The experiment is repeated for wires of the same material and same length L but different diameter d .

It is suggested that R and d are related by the equation

$$R = \frac{4\rho L}{\pi d^2}$$

where ρ is a constant.

- (a) A graph is plotted of R on the y -axis against $\frac{1}{d^2}$ on the x -axis.

Determine an expression for the gradient.

gradient =[1]

(b) Values of d and R are given in Fig. 2.2.

$d/10^{-3}\text{m}$	R/Ω	
0.91 ± 0.01	1.6	
0.56 ± 0.01	4.4	
0.46 ± 0.01	6.6	
0.38 ± 0.01	9.7	
0.32 ± 0.01	13.9	
0.27 ± 0.01	19.5	

Fig. 2.2

Calculate and record values of $\frac{1}{d^2}/10^6\text{m}^{-2}$ in Fig. 2.2.

Include the absolute uncertainties in $\frac{1}{d^2}$. [3]

(c) (i) Plot a graph of R/Ω against $\frac{1}{d^2}/10^6\text{m}^{-2}$.

Include error bars for $\frac{1}{d^2}$. [2]

(ii) Draw the straight line of best fit and a worst acceptable straight line on your graph. Both lines should be clearly labelled. [2]

(iii) Determine the gradient of the line of best fit. Include the absolute uncertainty in your answer.

gradient =[2]

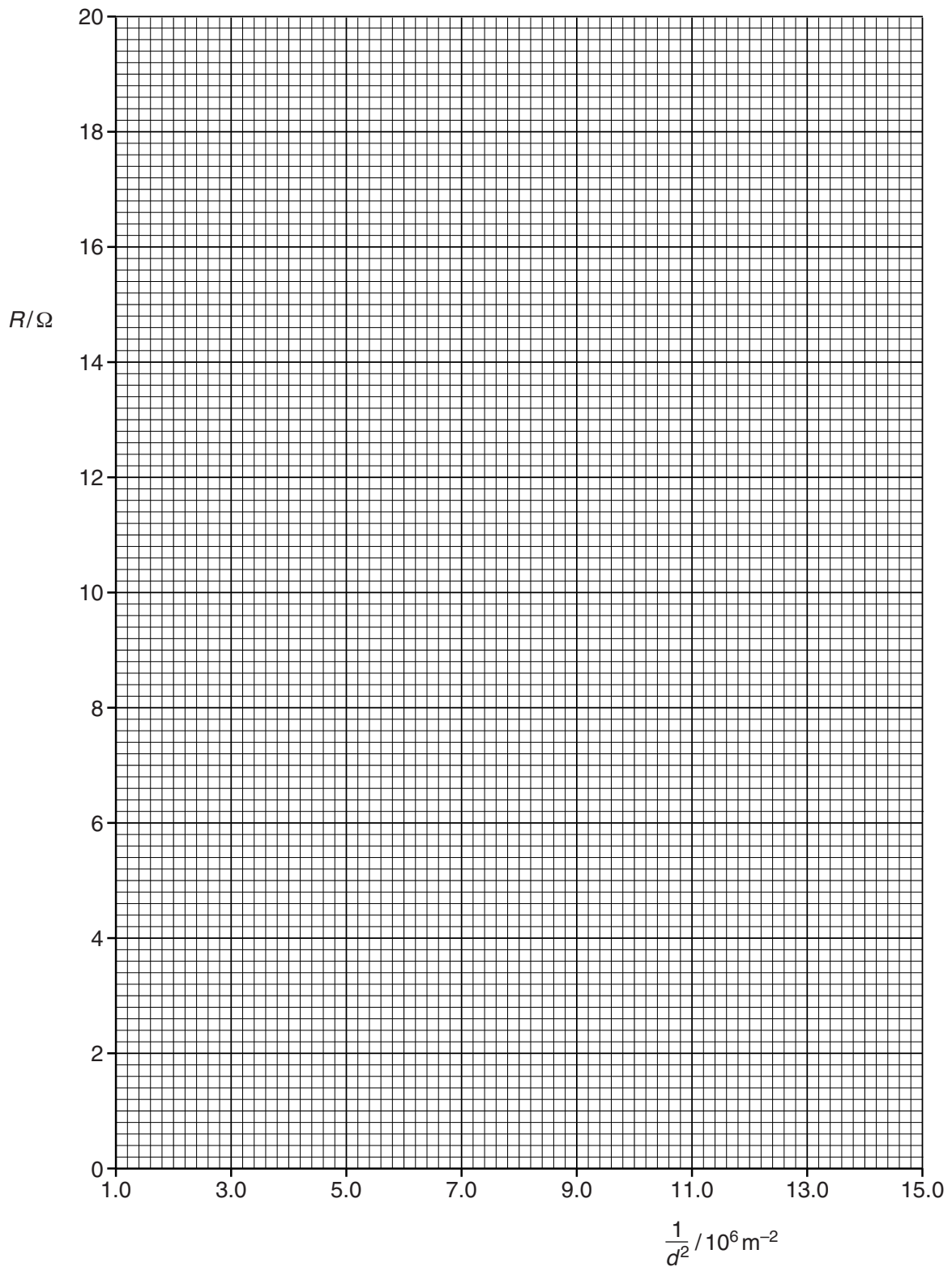

- (d) (i) Using your answers to (a) and (c)(iii), determine the value of ρ . Include an appropriate unit.

Data: $L = 1.00 \pm 0.01$ m.

$$\rho = \dots\dots\dots [2]$$

- (ii) Determine the percentage uncertainty in ρ .

$$\text{percentage uncertainty in } \rho = \dots\dots\dots \% [1]$$

- (e) The experiment is repeated with a thinner wire of diameter 0.23 ± 0.01 mm. The wire is of the same material and length.

Determine the resistance R of the wire. Include the absolute uncertainty in your answer.

$$R = \dots\dots\dots \Omega [2]$$

[Total: 15]