

Cambridge International AS & A Level

CANDIDATE
NAME

CENTRE
NUMBER

--	--	--	--	--

CANDIDATE
NUMBER

--	--	--	--



PHYSICS

9702/52

Paper 5 Planning, Analysis and Evaluation

May/June 2022

1 hour 15 minutes

You must answer on the question paper.

No additional materials are needed.

INSTRUCTIONS

- Answer **all** questions.
- Use a black or dark blue pen. You may use an HB pencil for any diagrams or graphs.
- Write your name, centre number and candidate number in the boxes at the top of the page.
- Write your answer to each question in the space provided.
- Do **not** use an erasable pen or correction fluid.
- Do **not** write on any bar codes.
- You may use a calculator.
- You should show all your working and use appropriate units.

INFORMATION

- The total mark for this paper is 30.
- The number of marks for each question or part question is shown in brackets [].

This document has 8 pages.

- 1 Two parallel cylindrical conductors each have a small cross-sectional area A . A thin metal bar connects the two conductors, as shown in Fig. 1.1.

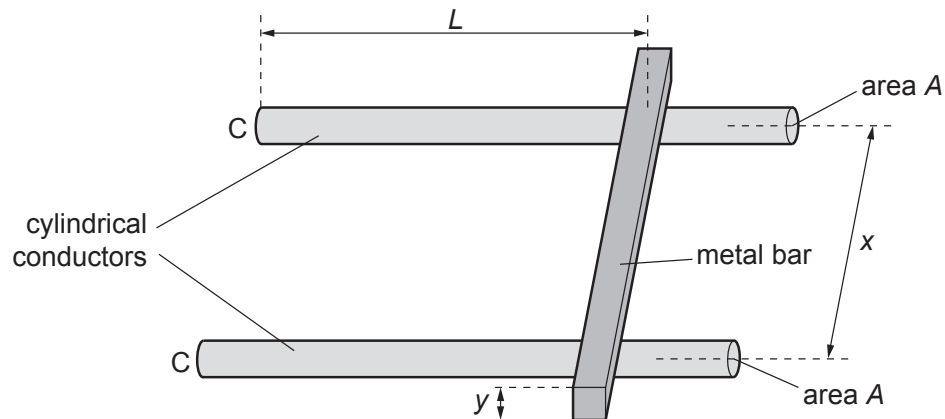

Fig. 1.1 (not to scale)

The metal bar has a square cross-section with sides of length y . For each conductor, the distance between its end C and the centre of the metal bar is L . The distance between the centres of the conductors is x .

The ends C are connected to a power supply and the current I in the conductors is measured.

It is suggested that I is related to L by the relationship

$$\frac{E}{I} = \frac{2PL}{A} + \frac{Qx}{y^2}$$

where E is the electromotive force (e.m.f.) of the power supply, and P and Q are constants.

Plan a laboratory experiment to test the relationship between I and L .

Draw a diagram showing the arrangement of your equipment.

Explain how the results could be used to determine values for P and Q .

In your plan you should include:

- the procedure to be followed
- the measurements to be taken
- the control of variables
- the analysis of the data
- any safety precautions to be taken.

- 2 The brightness of some stars varies regularly. These stars are called variable stars.

Fig. 2.1 shows the variation of luminosity with time for a variable star.

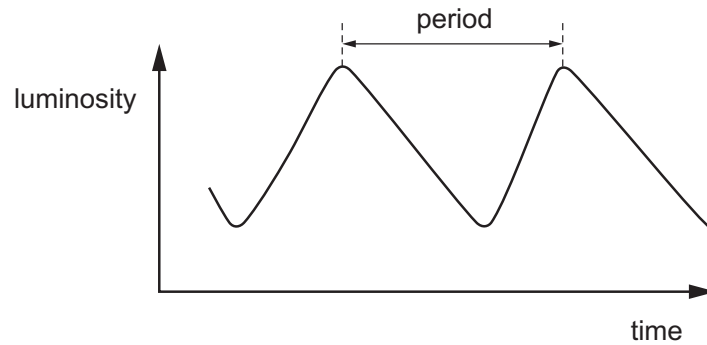

Fig. 2.1

A student determines the period T and mean luminosity L of the star.

The student repeats the process for different variable stars.

It is suggested that L and T are related by the equation

$$L = SKT^a$$

where S is the luminosity of the Sun, and a and K are constants.

- (a) A graph is plotted of $\lg L$ on the y -axis against $\lg T$ on the x -axis.

Determine expressions for the gradient and y -intercept.

gradient =

y -intercept =

[1]

(b) Values of T and L are given in Table 2.1.

Table 2.1

T/days	$L/10^{30}W$	$\lg(T/\text{days})$	$\lg(L/10^{30}W)$
22	2.9 ± 0.2		
32	4.9 ± 0.2		
42	6.9 ± 0.2		
54	9.8 ± 0.2		
78	16 ± 2		
97	21 ± 2		

Calculate and record values of $\lg(T/\text{days})$ and $\lg(L/10^{30}W)$ in Table 2.1.
Include the absolute uncertainties in $\lg(L/10^{30}W)$.

[2]

(c) (i) Plot a graph of $\lg(L/10^{30}W)$ against $\lg(T/\text{days})$.
Include error bars for $\lg(L/10^{30}W)$.

[2]

(ii) Draw the straight line of best fit and a worst acceptable straight line on your graph. Label both lines.

[2]

(iii) Determine the gradient of the line of best fit. Include the absolute uncertainty in your answer.

gradient = [2]

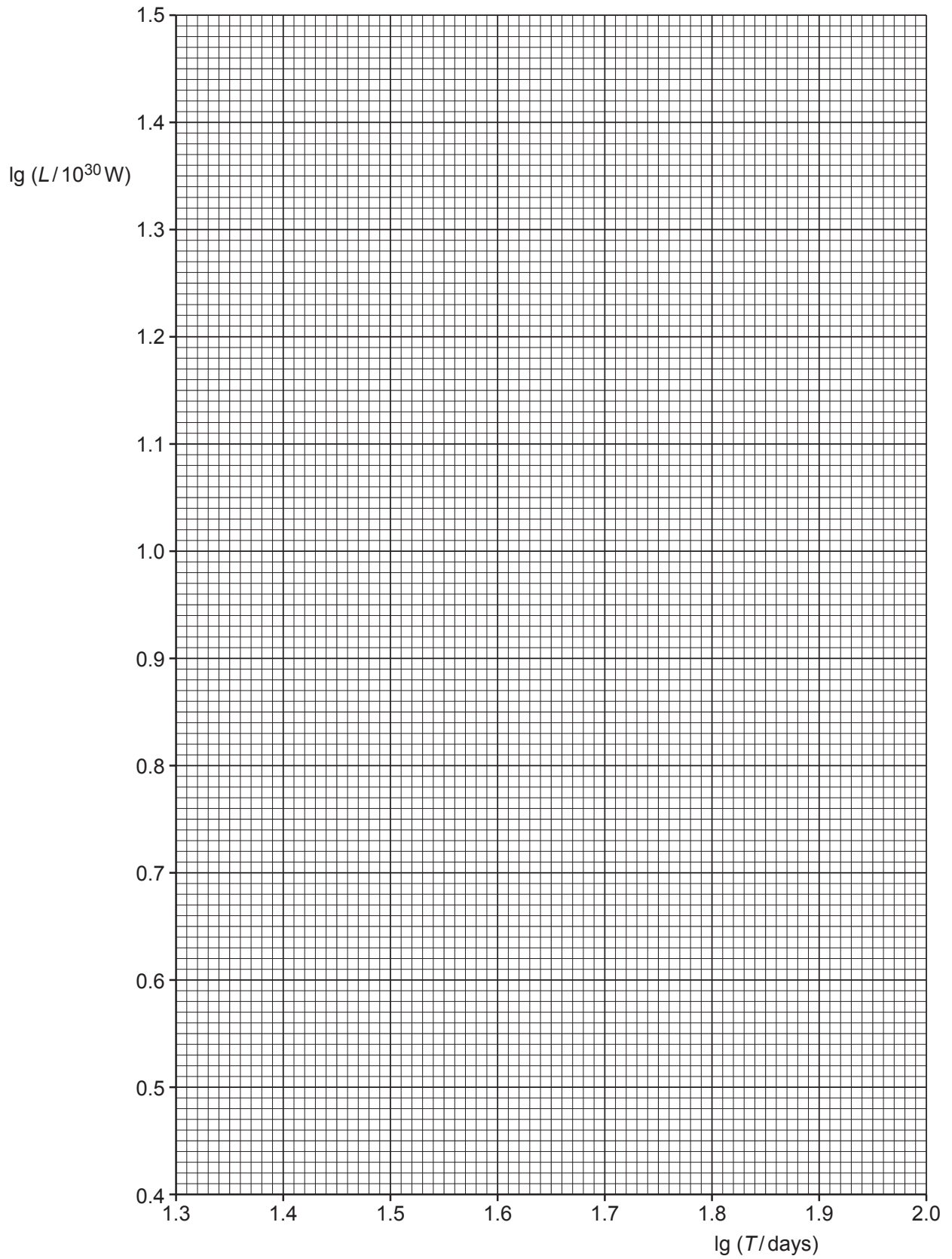

- (iv) Determine the y -intercept of the line of best fit. Include the absolute uncertainty in your answer.

y -intercept = [2]

- (d) Using your answers to (a), (c)(iii) and (c)(iv), determine the values of a and K . Include the absolute uncertainties in your values. You need not be concerned with units.

Data: $S = 3.85 \times 10^{26} \text{ W}$

$a = \dots\dots\dots$

$K = \dots\dots\dots$ [3]

- (e) A variable star has a period of 5.0 days.

Determine the luminosity L of this star.

$L = \dots\dots\dots \text{ W}$ [1]

[Total: 15]