

# Pearson Edexcel International Advanced Level

**Tuesday 13 January 2026**

Afternoon (Time: 1 hour 30 minutes)

Paper  
reference

**WPH12/01A**

## **Physics**

**International Advanced Subsidiary/Advanced Level**

**UNIT 2: Waves and Electricity**

**Question Paper**

### **You must have:**

Scientific calculator, ruler, protractor and Answer Book

Do not return this question paper with the Answer Book

### **Information**

- The list of data, formulae and relationships is printed at the end of this booklet.

Turn over ►

**P87635A**

©2026 Pearson Education Ltd.  
C:1/1/1/1/1/



**Pearson**

## SECTION A

Answer ALL questions.

1 Which of the following units is equivalent to the volt?

- A  $\text{Js}^{-1}$
- B  $\text{Ws}^{-1}$
- C  $\text{JC}^{-1}$
- D  $\text{WC}^{-1}$

(Total for Question 1 = 1 mark)

---

2 The diagram shows five energy levels in an atom.

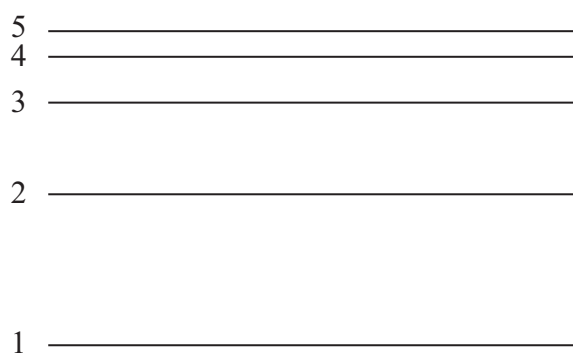

Electromagnetic radiation is incident on the atom.

Which transition would be caused by the absorption of the lowest frequency of radiation?

- A 1 to 5
- B 1 to 2
- C 4 to 5
- D 5 to 4

(Total for Question 2 = 1 mark)

---



3 Which of the following graphs shows how current  $I$  varies with potential difference  $V$  for a negative temperature coefficient thermistor?

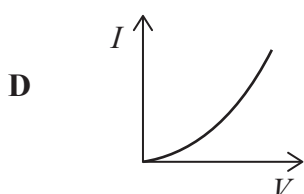
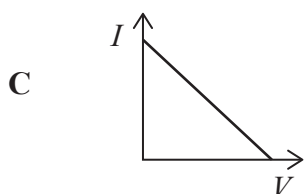
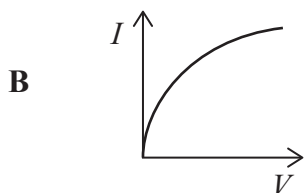
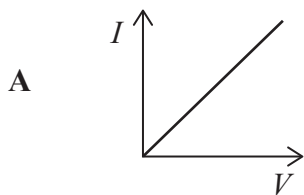

(Total for Question 3 = 1 mark)

4 The de Broglie wavelength for a moving electron is  $5.47 \times 10^{-10}$  m

Which of the following expressions gives the speed of the electron in  $\text{ms}^{-1}$ ?

A 
$$\frac{(6.63 \times 10^{-34})}{(9.11 \times 10^{-31})(5.47 \times 10^{-10})}$$

B 
$$\frac{(6.63 \times 10^{-34})}{(1.60 \times 10^{-19})(5.47 \times 10^{-10})}$$

C 
$$\frac{(9.11 \times 10^{-31})(5.47 \times 10^{-10})}{6.63 \times 10^{-34}}$$

D 
$$\frac{(1.60 \times 10^{-19})(5.47 \times 10^{-10})}{(6.63 \times 10^{-34})}$$

(Total for Question 4 = 1 mark)

**5** As temperature increases, the resistance of a negative temperature coefficient thermistor changes.

Which of the following describes the reason for this change?

- A** Collisions between electrons and ions occur less frequently.
- B** More conduction electrons are released.
- C** The ions in the thermistor vibrate less.
- D** The ions in the thermistor vibrate more.

**(Total for Question 5 = 1 mark)**

---



**Questions 6 and 7 refer to the following information.**

The diagram shows a circuit used to determine the internal resistance  $r$  and e.m.f.  $\varepsilon$  of a cell.

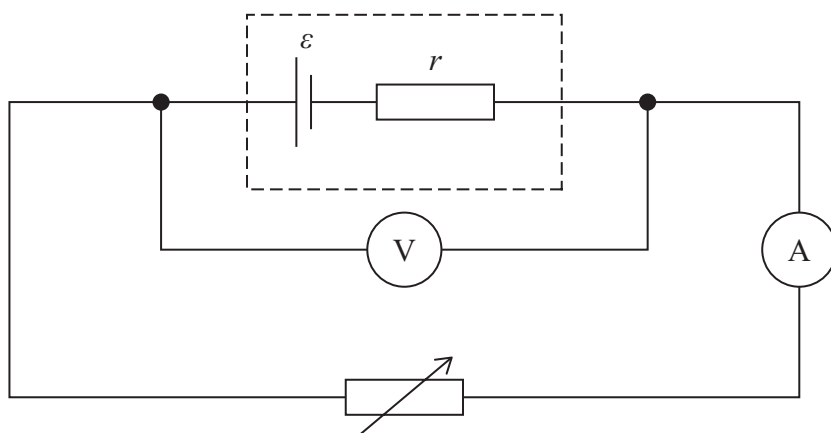

- 6 Corresponding values of potential difference  $V$  and current  $I$  were taken after adjusting the variable resistor. A graph of  $V$  on the  $y$ -axis and  $I$  on the  $x$ -axis was plotted.

Which of the following is correct?

- A The area underneath the graph is the total energy dissipated in the cell.
- B The gradient of the graph is  $r$ .
- C The graph shows that  $V$  and  $I$  are directly proportional.
- D The  $y$ -intercept of the graph is  $\varepsilon$ .

**(Total for Question 6 = 1 mark)**

- 7 The resistance of the variable resistor is  $R$ .

Which of the following gives the current in the cell?

- A  $\frac{\varepsilon}{R}$
- B  $\frac{\varepsilon}{r}$
- C  $\frac{\varepsilon}{(R + r)}$
- D  $\frac{\varepsilon}{(R - r)}$

**(Total for Question 7 = 1 mark)**

8 Which of the following statements is correct for plane polarised light?

- A The oscillations are in a single plane, including the direction of energy transfer.
- B The oscillations are in a single plane, which is perpendicular to the direction of energy transfer.
- C The oscillations are in many planes, which are perpendicular to the direction of energy transfer.
- D The oscillations are in many planes, which include the direction of energy transfer.

(Total for Question 8 = 1 mark)

9 The diagram shows a uniform wire XY across which a potential difference  $V_0$  is applied.

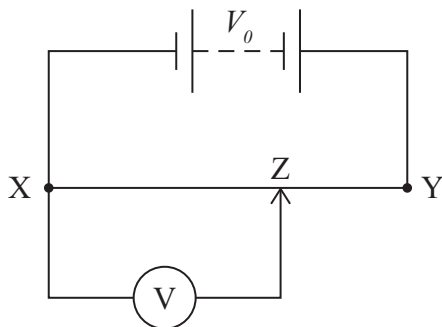

Which of the following correctly shows the output potential difference across XZ?

- A  $V = \frac{XZ}{XY} V_0$
- B  $V = \frac{XZ}{ZY} V_0$
- C  $V = \frac{ZY}{XY} V_0$
- D  $V = \frac{XY}{XZ} V_0$

(Total for Question 9 = 1 mark)



10 The diagram below shows a standing wave on a string.

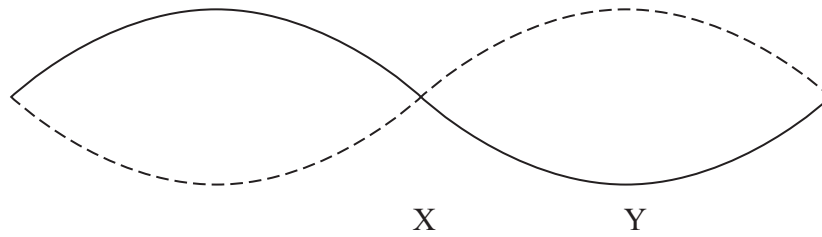

A standing wave is created when two progressive waves travelling in opposite directions combine.

Which of the following correctly indicates the phase difference between the progressive waves at X and the phase difference between the progressive waves at Y?

	Phase difference between progressive waves at X	Phase difference between progressive waves at Y
A	$\pi$	$\pi$
B	$\pi$	$2\pi$
C	$2\pi$	$\pi$
D	$2\pi$	$2\pi$

(Total for Question 10 = 1 mark)

---

**TOTAL FOR SECTION A = 10 MARKS**



## SECTION B

11 The image shows a satellite television dish.

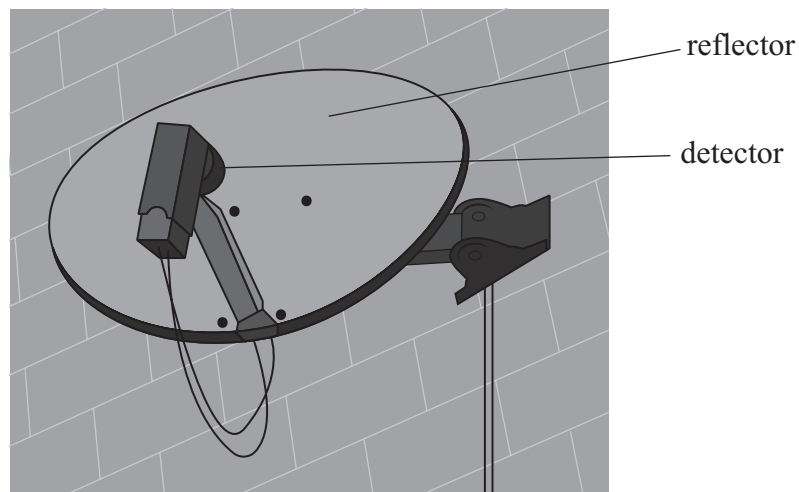

Electromagnetic radiation from a communications satellite is reflected from the reflector to the detector.

(a) The radiation used has a frequency of 12.6 GHz.

Calculate the wavelength of the radiation.

(2)

(b) The intensity of the radiation incident on the reflector is  $4.8 \times 10^{-13} \text{ W m}^{-2}$ .

Calculate the power of the incident radiation.

area of satellite dish =  $0.27 \text{ m}^2$

(2)

(Total for Question 11 = 4 marks)



- 12 A student investigates the resistance of the ‘lead’ in a pencil. A pencil is used to draw a rectangle, of length 2.0 cm and width 6.0 mm, on paper, creating a strip of unknown thickness  $t$ .

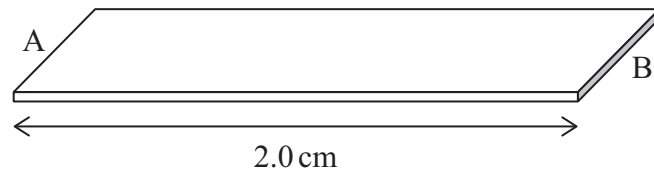

Not to scale

- (a) The resistance of the strip between ends A and B is  $55 \text{ k}\Omega$

resistivity of this pencil lead =  $3.5 \times 10^{-5} \Omega\text{m}$

Show that the cross-sectional area of the strip of pencil lead is about  $1 \times 10^{-11} \text{ m}^2$

(2)

- (b) The pencil lead is made of a mixture of graphite and clay. The pencil has 50% graphite and 50% clay.

charge carrier density  $n$  for pure graphite is  $3.5 \times 10^{24} \text{ m}^{-3}$

Calculate the drift velocity for the charge carriers in the pencil lead when a potential difference of 6.0 V is applied across the strip from A to B.

Assume the clay contributes no charge carriers.

(4)

- (c) Pencil leads are made with a hardness from 9H (very hard) to 9B (very soft).

Hard pencil leads have a higher proportion of clay.

Explain how the resistance of the strip would be affected if it were drawn with a softer pencil.

(2)

**(Total for Question 12 = 8 marks)**

**13** Ultrasound can be used to check for cracks in metal beams.

A transducer emits a pulse of ultrasound into a metal beam. The same transducer detects the returning pulses.

Part of a metal beam is shown. The beam contains 3 cracks, A, B and C.

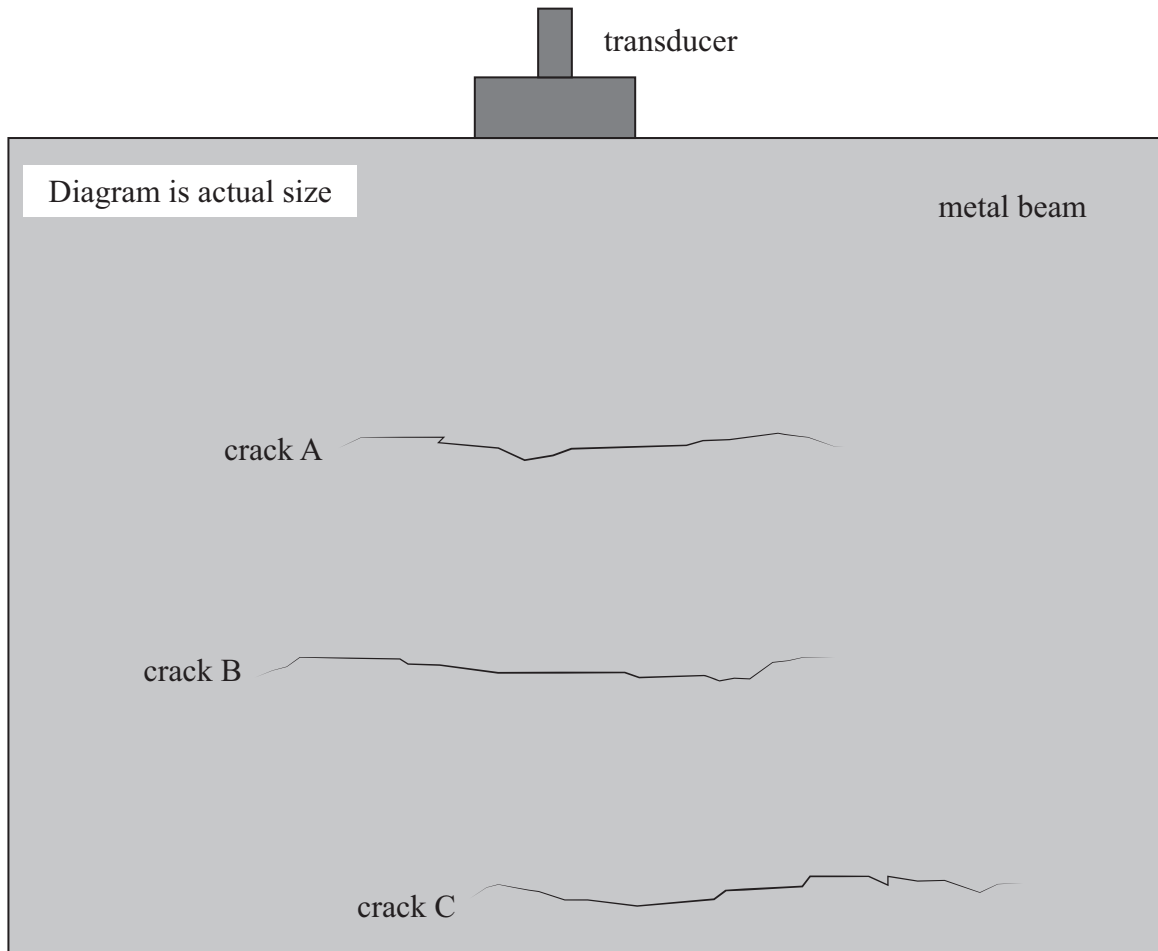

The transducer detects a returning pulse from each crack.

(a) Explain why there is a returning pulse from crack B. (3)

(b) One pulse returns  $1.4 \times 10^{-5}$  s after being emitted by the transducer.

Deduce whether the pulse has returned from crack A, crack B or crack C.

You should take measurements from the diagram.

speed of ultrasound in metal =  $5900 \text{ ms}^{-1}$  (3)



(c) Explain why ultrasound used to detect cracks in metal beams usually has frequencies of MHz rather than kHz.

(2)

**(Total for Question 13 = 8 marks)**

---



14 Drivers use car headlights to emit light in dark conditions.

The graph shows how current  $I$  varies with the potential difference  $V$  for a car headlight.

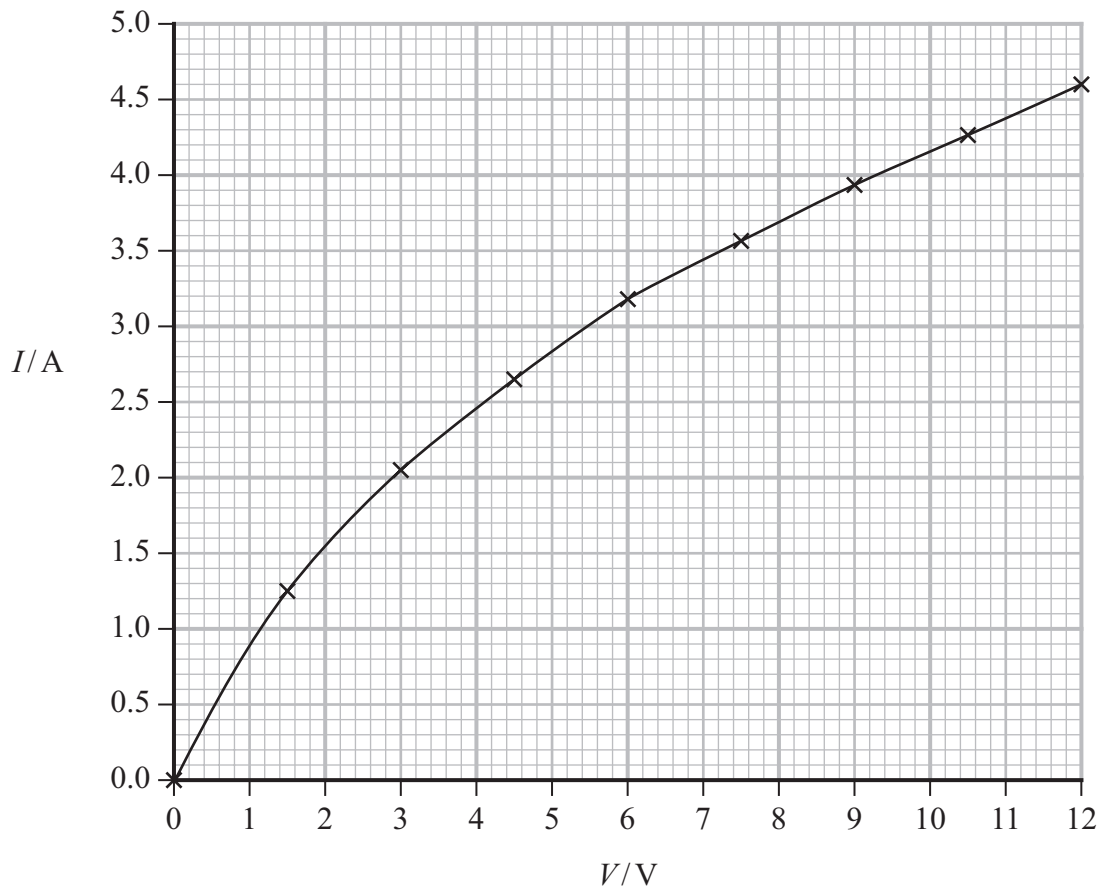

The headlight will emit light when it dissipates at least 35 W of power.

- (a) Determine the minimum potential difference for which the headlight will emit light. (3)
- (b) In a car, two headlights are connected in parallel with a 12.0 V battery. The battery has negligible internal resistance.
- (i) Explain the advantages of connecting the headlights in parallel with the battery rather than in series. (3)



(ii) A student writes the following statement.

When connected to the 12.0 V battery, the combined resistance of two headlights in parallel is one quarter of the combined resistance of two headlights in series.

Deduce whether the student is correct.

Your answer should include calculations using data from the graph.

(3)

**(Total for Question 14 = 9 marks)**

---



15 The photograph shows a musical instrument called a harp.



When a harp string is plucked, transverse waves travel along the string forming a standing wave.

(a) State what is meant by a transverse wave.

(1)

(b) The string is initially made to vibrate at its lowest frequency but the string can also be made to vibrate at higher frequencies.

Add to the diagram in the answer book, to show the first stationary wave on the string when it is vibrating at a higher frequency.

You should label any nodes and antinodes.



(3)



- (c) For one string, the tension in the string is 41 N and the wave travels at a speed of  $141 \text{ m s}^{-1}$ .

This string breaks and needs replacing with a new string.

The table shows the mass of four new strings, A, B, C and D.

Each new string has a length of 1.5 m

String	Mass of string / g
A	1.5
B	3.1
C	4.4
D	6.3

The new string is cut to the same length as the broken string, and is placed under the same tension.

Deduce which new string, A, B, C or D, should be used to replace the broken string.

(3)

**(Total for Question 15 = 7 marks)**

---



16 Dishwashing machines use a solution known as rinse aid to prevent water from leaving marks on the dishes as they dry.

(a) A student carries out an experiment to determine the refractive index of rinse aid.

The photograph shows a ray of light passing through a rectangular container of rinse aid.

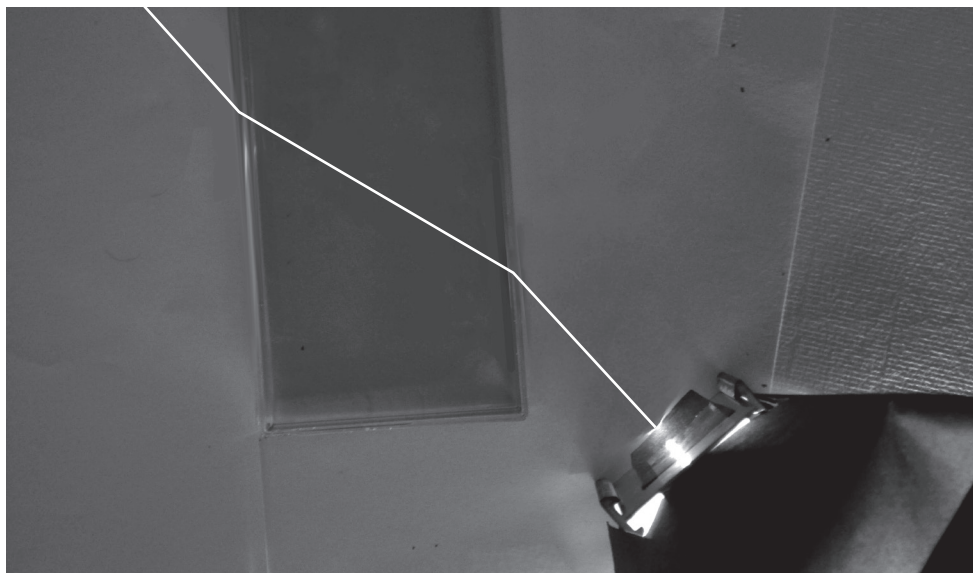

Determine the refractive index of the rinse aid.

You may ignore any effect from the container.

(3)

(b) The rinse aid is stored in a small reservoir in the dishwasher with an optical dipstick to indicate the level of the liquid.

The dipstick is a clear plastic cylinder with a pointed end that dips into the liquid.

Show that the critical angle for light in the plastic, when surrounded by rinse aid, is about  $60^\circ$ .

speed of light in rinse aid =  $2.22 \times 10^8 \text{ ms}^{-1}$

speed of light in plastic =  $2.00 \times 10^8 \text{ ms}^{-1}$

(3)



(c) The images below show the difference between the appearance, from above, of the dipstick when the reservoir is empty and when it is full.



Appearance from above when empty

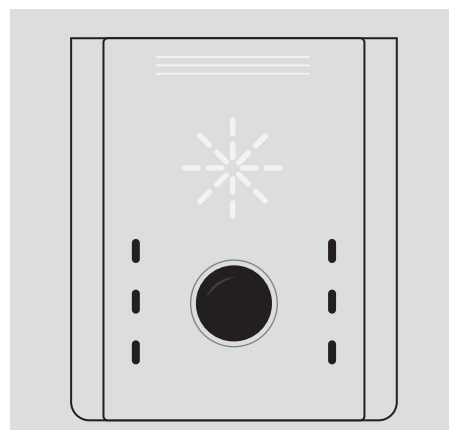

Appearance from above when full

When the reservoir is empty, the dipstick is surrounded by air. It appears light because light from the surroundings is reflected back to the viewer.

When the reservoir is full, the dipstick is surrounded by rinse aid and appears dark.

The diagrams below show side views of the dipstick.

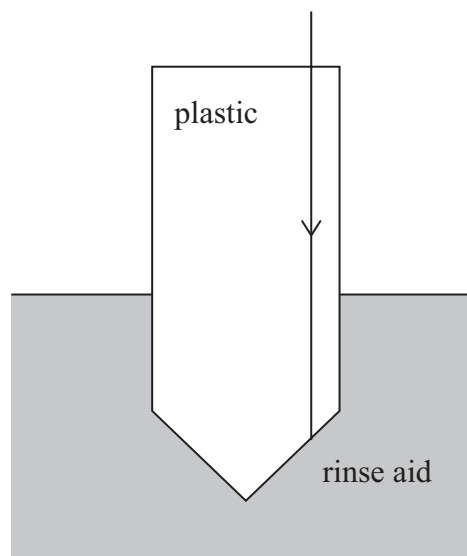
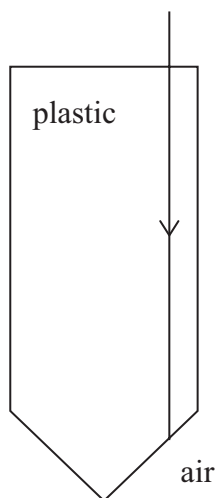

Complete the diagrams to show the paths of light when the rinse aid level is low and when it is high.

critical angle for plastic surrounded by air =  $42^\circ$

(4)

(Total for Question 16 = 10 marks)

\*17 The list of data, formulae and relationships for this paper states the following:

$$\text{Einstein's photoelectric equation } hf = \phi + \frac{1}{2}mv_{\text{max}}^2$$

Describe the photoelectric effect, including an explanation of each of the terms,  $hf$ ,  $\phi$  and  $\frac{1}{2}mv_{\text{max}}^2$ , in the equation.

(Total for Question 17 = 6 marks)

---



18 The speed of sound in sea water varies with depth, as shown in diagram A.

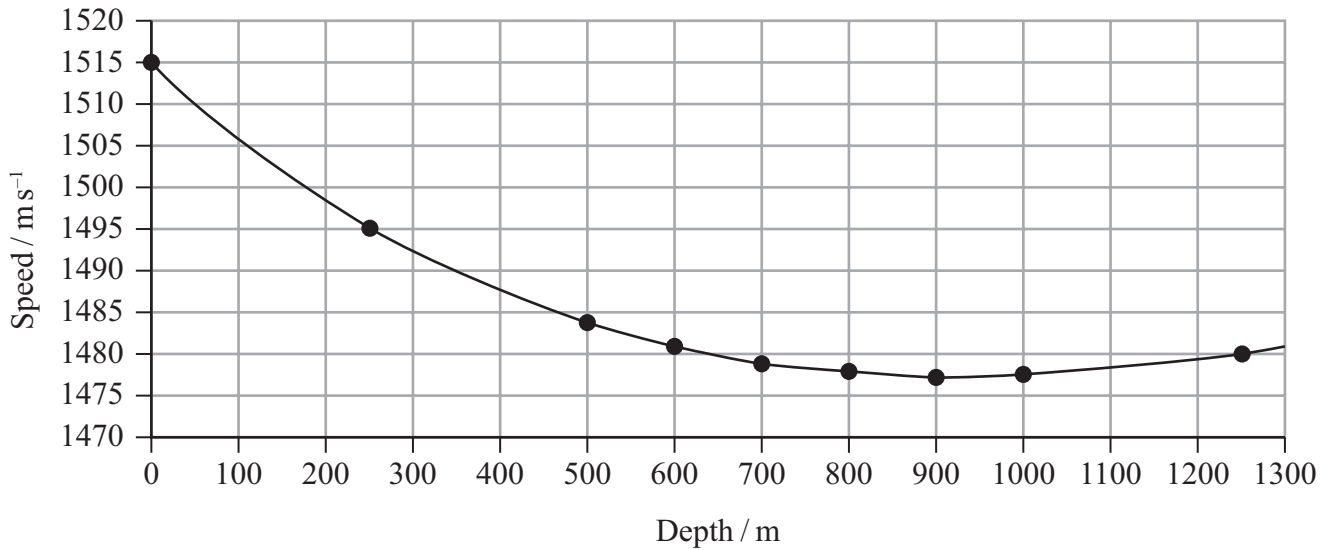

Diagram A

Sound produced at a depth of 900 m initially travels towards the water surface. As the sound approaches a depth of 700 m, it changes direction and follows the path shown to the point P in diagram B.

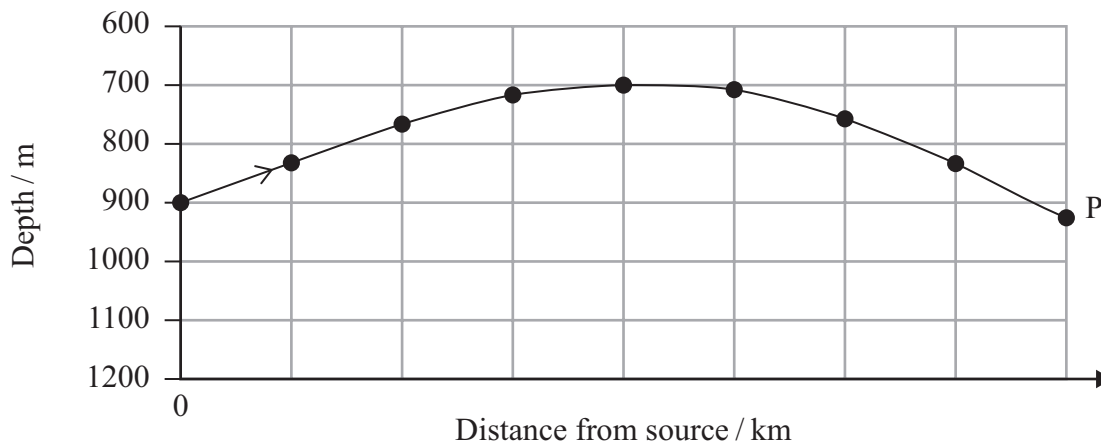

Diagram B



(a) Explain why the sound follows the path shown in diagram B.

Your answer should refer to refraction and diagram A.

(5)

(b) Sound that travels in a straight line from the source to point P takes longer to arrive than sound that travels along the path shown in diagram B.

Suggest why.

(2)

(c) Suggest two factors that might cause the speed of sound to vary with the depth of the sea.

(2)

**(Total for Question 18 = 9 marks)**

---



- 19 A laser, a diffraction grating and a screen are setup as shown. The laser emits monochromatic light.



When the laser is switched on, a series of bright dots is seen on the screen.

- (a) The diagram below shows the position of the central dot at O. The next bright dot appears at position X.

The diffraction grating has 450 lines per mm.

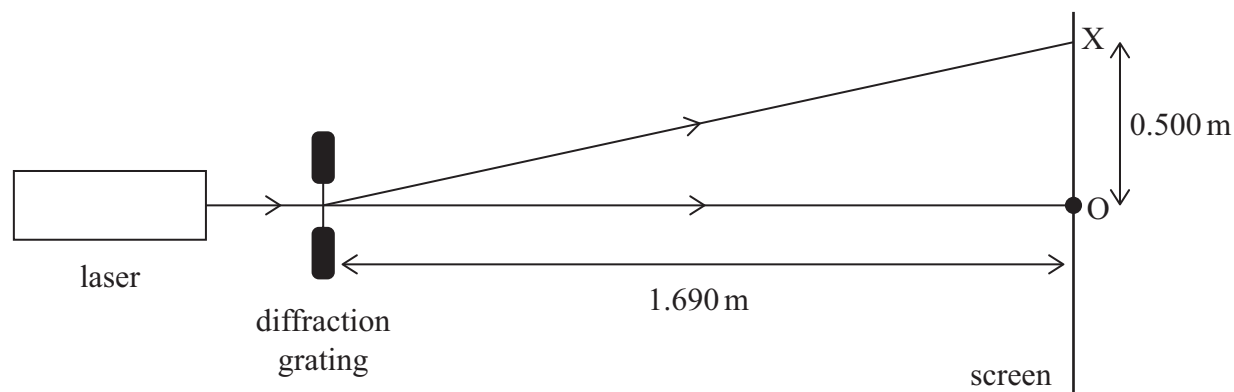

Determine the wavelength of the light from the laser.

(4)

- (b) Explain why a series of bright dots is seen on the screen.

(3)

- (c) The laser is replaced by a source producing a parallel beam of bright white light.

Suggest what would not be observed on the screen.

(2)

(Total for Question 19 = 9 marks)

**TOTAL FOR SECTION B = 70 MARKS**  
**TOTAL FOR PAPER = 80 MARKS**



### List of data, formulae and relationships

Acceleration of free fall	$g = 9.81 \text{ m s}^{-2}$	(close to Earth's surface)
Electron charge	$e = -1.60 \times 10^{-19} \text{ C}$	
Electron mass	$m_e = 9.11 \times 10^{-31} \text{ kg}$	
Electronvolt	$1 \text{ eV} = 1.60 \times 10^{-19} \text{ J}$	
Gravitational field strength	$g = 9.81 \text{ N kg}^{-1}$	(close to Earth's surface)
Planck constant	$h = 6.63 \times 10^{-34} \text{ J s}$	
Speed of light in a vacuum	$c = 3.00 \times 10^8 \text{ m s}^{-1}$	

#### Unit 1

##### Mechanics

Kinematic equations of motion	$s = \frac{(u + v)t}{2}$
	$v = u + at$
	$s = ut + \frac{1}{2}at^2$
	$v^2 = u^2 + 2as$

Forces	$\Sigma F = ma$
	$g = \frac{F}{m}$
	$W = mg$

Momentum	$p = mv$
----------	----------

Moment of force	moment = $Fx$
-----------------	---------------

Work and energy	$\Delta W = F\Delta s$
	$E_k = \frac{1}{2}mv^2$
	$\Delta E_{\text{grav}} = mg\Delta h$

Power	$P = \frac{E}{t}$
	$P = \frac{W}{t}$



Efficiency

$$\text{efficiency} = \frac{\text{useful energy output}}{\text{total energy input}}$$

$$\text{efficiency} = \frac{\text{useful power output}}{\text{total power input}}$$

*Materials*

Density

$$\rho = \frac{m}{V}$$

Stokes' law

$$F = 6\pi\eta r v$$

Hooke's law

$$\Delta F = k\Delta x$$

Elastic strain energy

$$\Delta E_{\text{el}} = \frac{1}{2}F\Delta x$$

Young modulus

$$E = \frac{\sigma}{\varepsilon} \text{ where}$$

$$\text{Stress } \sigma = \frac{F}{A}$$

$$\text{Strain } \varepsilon = \frac{\Delta x}{x}$$



## Unit 2

### Waves

Wave speed	$v = f\lambda$
Speed of a transverse wave on a string	$v = \sqrt{\frac{T}{\mu}}$
Intensity of radiation	$I = \frac{P}{A}$
Refractive index	$n_1 \sin \theta_1 = n_2 \sin \theta_2$ $n = \frac{c}{v}$
Critical angle	$\sin C = \frac{1}{n}$
Diffraction grating	$n\lambda = d \sin \theta$

### Electricity

Potential difference	$V = \frac{W}{Q}$
Resistance	$R = \frac{V}{I}$
Electrical power, energy	$P = VI$ $P = I^2R$ $P = \frac{V^2}{R}$ $W = VI t$
Resistivity	$R = \frac{\rho l}{A}$
Current	$I = \frac{\Delta Q}{\Delta t}$ $I = nqvA$
Resistors in series	$R = R_1 + R_2 + R_3$
Resistors in parallel	$\frac{1}{R} = \frac{1}{R_1} + \frac{1}{R_2} + \frac{1}{R_3}$

### Particle nature of light

Photon model	$E = hf$
Einstein's photoelectric equation	$hf = \phi + \frac{1}{2}mv_{\max}^2$
de Broglie wavelength	$\lambda = \frac{h}{p}$



Please check the examination details below before entering your candidate information

Candidate surname

Other names

Centre Number

Candidate Number

**Pearson Edexcel International Advanced Level**

**Tuesday 13 January 2026**

Afternoon (Time: 1 hour 30 minutes)

Paper  
reference

**WPH12/01A**

**Physics**

**International Advanced Subsidiary/Advanced Level**

**UNIT 2: Waves and Electricity**

**Answer book**

**You must have:**

Scientific calculator, ruler, protractor, and Question paper

Total Marks

### Instructions

- Use **black** ink or ball-point pen.
- If pencil is used for diagrams/sketches/graphs it must be dark (HB or B).
- **Fill in the boxes** at the top of this page with your name, centre number and candidate number.
- Answer **all** questions.
- Answer the questions in the spaces provided  
– *there may be more space than you need.*
- **Show all your working out** in calculations and **include units** where appropriate.

### Information

- The total mark for this paper is 80.
- The marks for **each** question are shown in brackets  
– *use this as a guide as to how much time to spend on each question.*

### Advice

- Read each question carefully before you start to answer it.
- Try to answer every question.
- Check your answers if you have time at the end.

Turn over ►

P87618A

©2026 Pearson Education Ltd.  
C:1/1/1/1/1/



  
Pearson

## SECTION A

Answer ALL questions.

For questions 1–10, in Section A, select one answer from A to D and put a cross in the box ☒. If you change your mind, put a line through the box ☒ and then mark your new answer with a cross ☒.

Write the answers to Questions 1 to 10 on these 3 pages.

1

- A
- B
- C
- D

(Total for Question 1 = 1 mark)

2

- A
- B
- C
- D

(Total for Question 2 = 1 mark)

3

- A
- B
- C
- D

(Total for Question 3 = 1 mark)

DO NOT WRITE IN THIS AREA

DO NOT WRITE IN THIS AREA

DO NOT WRITE IN THIS AREA



4

- A
- B
- C
- D

(Total for Question 4 = 1 mark)

5

- A
- B
- C
- D

(Total for Question 5 = 1 mark)

6

- A
- B
- C
- D

(Total for Question 6 = 1 mark)

7

- A
- B
- C
- D

(Total for Question 7 = 1 mark)



8

- A
- B
- C
- D

(Total for Question 8 = 1 mark)

9

- A
- B
- C
- D

(Total for Question 9 = 1 mark)

10

- A
- B
- C
- D

(Total for Question 10 = 1 mark)

**TOTAL FOR SECTION A = 10 MARKS**



DO NOT WRITE IN THIS AREA

DO NOT WRITE IN THIS AREA

DO NOT WRITE IN THIS AREA

**SECTION B**

**Answer ALL questions in the spaces provided.**

**11 (a)**

(2)

.....

.....

.....

Wavelength = .....

**(b)**

(2)

.....

.....

.....

Power = .....

**(Total for Question 11 = 4 marks)**



12 (a)

(2)

.....

.....

.....

DO NOT WRITE IN THIS AREA

DO NOT WRITE IN THIS AREA

DO NOT WRITE IN THIS AREA

(b)

(4)

.....

.....

.....

.....

Drift velocity = .....

(c)

(2)

.....

.....

.....

.....

.....

**(Total for Question 12 = 8 marks)**



13 (a)

(3)

DO NOT WRITE IN THIS AREA

DO NOT WRITE IN THIS AREA

DO NOT WRITE IN THIS AREA

.....

.....

.....

.....

.....



(b)

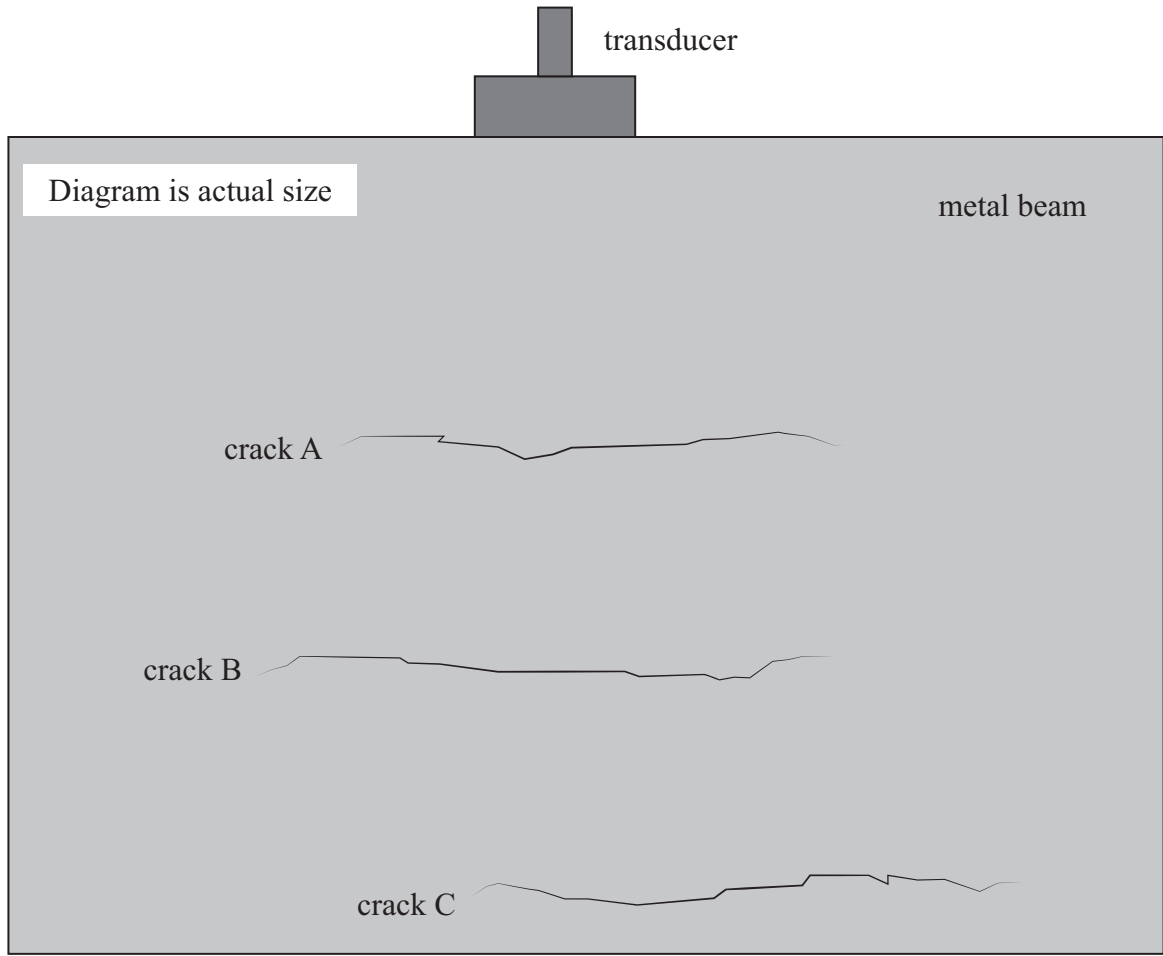

(3)

DO NOT WRITE IN THIS AREA

DO NOT WRITE IN THIS AREA

DO NOT WRITE IN THIS AREA





14 (a)

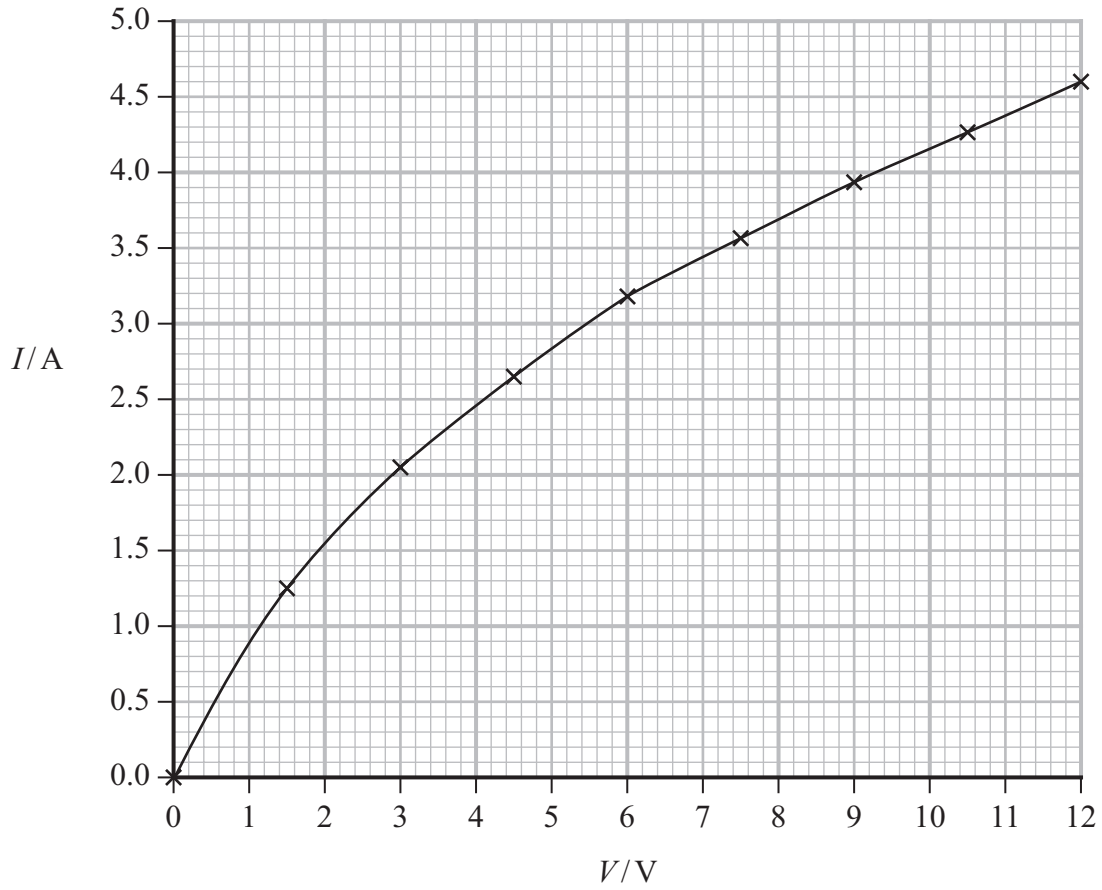

(3)

Minimum potential difference = ..... V

(b) (i)

(3)



(ii)

(3)

.....

.....

.....

.....

.....

.....

**(Total for Question 14 = 9 marks)**

DO NOT WRITE IN THIS AREA

DO NOT WRITE IN THIS AREA

DO NOT WRITE IN THIS AREA



15 (a)

(1)

---

---

(b)

(3)



DO NOT WRITE IN THIS AREA

DO NOT WRITE IN THIS AREA

DO NOT WRITE IN THIS AREA



DO NOT WRITE IN THIS AREA

DO NOT WRITE IN THIS AREA

DO NOT WRITE IN THIS AREA

(c)

(3)

Handwriting practice area with 15 horizontal dotted lines.

**(Total for Question 15 = 7 marks)**

Large blank area for writing the answer to question 15.



16 (a)

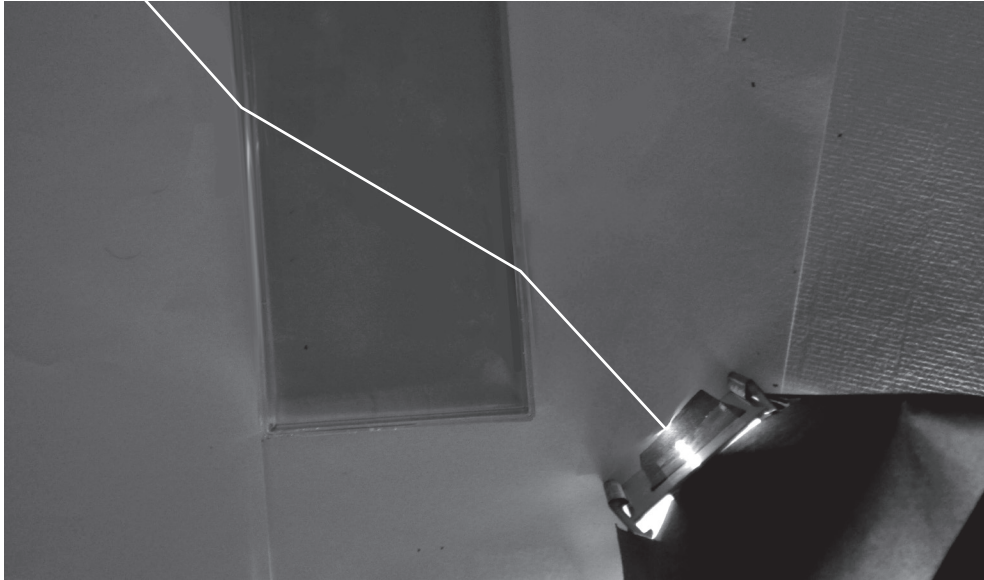

(3)

.....

.....

.....

.....

.....

.....

Refractive index = .....

DO NOT WRITE IN THIS AREA

DO NOT WRITE IN THIS AREA

DO NOT WRITE IN THIS AREA



DO NOT WRITE IN THIS AREA

DO NOT WRITE IN THIS AREA

DO NOT WRITE IN THIS AREA

(b)

(3)

.....

.....

.....

.....

.....

(c)

(4)

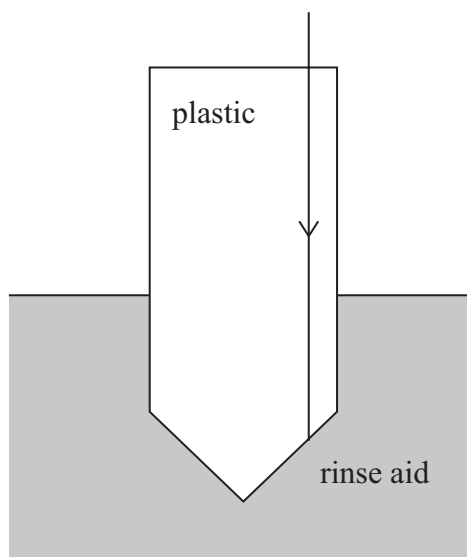
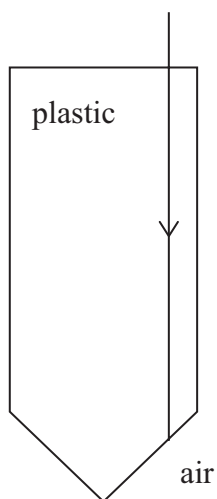

(Total for Question 16 = 10 marks)

.....

.....

.....

.....

.....



P 8 7 6 1 8 A 0 1 5 2 0

\*17

Handwriting practice area with 20 horizontal dotted lines.

(Total for Question 17 = 6 marks)

DO NOT WRITE IN THIS AREA

DO NOT WRITE IN THIS AREA

DO NOT WRITE IN THIS AREA



DO NOT WRITE IN THIS AREA

DO NOT WRITE IN THIS AREA

DO NOT WRITE IN THIS AREA

18 (a)

(5)

.....

.....

.....

.....

.....

.....

.....

.....

.....

.....

.....

(b)

(2)

.....

.....

.....

.....

.....

(c)

(2)

.....

.....

.....

.....

.....

(Total for Question 18 = 9 marks)

.....



19 (a)

(4)

.....

.....

.....

.....

.....

.....

.....

Wavelength = .....

(b)

(3)

.....

.....

.....

.....

.....

.....

DO NOT WRITE IN THIS AREA

DO NOT WRITE IN THIS AREA

DO NOT WRITE IN THIS AREA



DO NOT WRITE IN THIS AREA

DO NOT WRITE IN THIS AREA

DO NOT WRITE IN THIS AREA

(c)

(2)

---

---

---

---

---

(Total for Question 19 = 9 marks)

---

**TOTAL FOR SECTION B = 70 MARKS**  
**TOTAL FOR PAPER = 80 MARKS**



DO NOT WRITE IN THIS AREA

DO NOT WRITE IN THIS AREA

DO NOT WRITE IN THIS AREA

**BLANK PAGE**

