

2

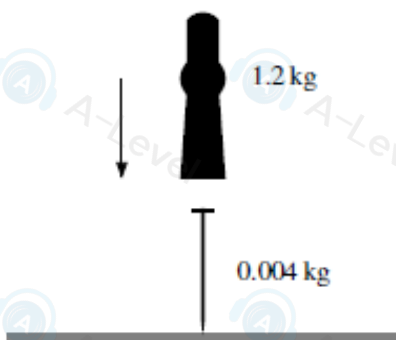

A machine for driving a nail into a block of wood causes a hammerhead to drop vertically onto the top of a nail. The mass of the hammerhead is 1.2 kg and the mass of the nail is 0.004 kg (see diagram). The hammerhead hits the nail with speed $v \text{ ms}^{-1}$ and remains in contact with the nail after the impact. The combined hammerhead and nail move immediately after the impact with speed 40 ms^{-1} .

- (a) Calculate v , giving your answer as an exact fraction.

[2]

.....

.....

.....

.....

- (b) The nail is driven 4 cm into the wood.

Find the constant force resisting the motion.

[3]

.....

.....

.....

.....

.....

.....

.....

.....

.....

- (c) Find the greatest acceleration of the particle during the first 10 seconds of its motion. [3]

The cyclist comes to the top of a hill inclined at 5° to the horizontal. The cyclist stops pedalling and freewheels down the hill (so that the cyclist is no longer supplying any power). The magnitude of the resistance force remains at 30 N . Over a distance of $d\text{ m}$, the speed of the cyclist increases from 6 ms^{-1} to 12 ms^{-1} .

- (b) Find the change in kinetic energy. [2]

.....

.....

.....

.....

.....

.....

.....

.....

- (c) Use an energy method to find d . [3]

.....

.....

.....

.....

.....

.....

.....

.....

.....

.....

- (b) Find the acceleration of the particle between $t = 0$ and $t = 5$, given that it is constant. [2]

.....

.....

.....

.....

.....

.....

.....

.....

.....

.....

.....

.....

.....

.....

.....

.....

.....

.....

.....

.....

.....

.....

- (c) Find the average speed of the particle during its motion. [2]

.....

.....

.....

.....

.....

.....

.....

.....

.....

.....

.....

.....

.....

.....

.....

.....

.....

.....

.....

.....

.....

.....

6

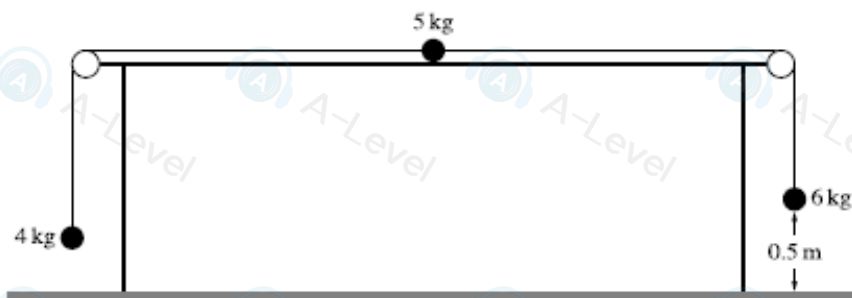

The diagram shows a particle of mass 5 kg on a rough horizontal table, and two light inextensible strings attached to it passing over smooth pulleys fixed at the edges of the table. Particles of masses 4 kg and 6 kg hang freely at the ends of the strings. The particle of mass 6 kg is 0.5 m above the ground. The system is in limiting equilibrium.

- (a) Show that the coefficient of friction between the 5 kg particle and the table is 0.4. [2]

.....

.....

.....

.....

.....

.....

The 6 kg particle is now replaced by a particle of mass 8 kg and the system is released from rest.

- (b) Find the acceleration of the 4 kg particle and the tensions in the strings. [5]

.....

.....

.....

.....

.....

.....

.....

- (c) In the subsequent motion the 8 kg particle hits the ground and does not rebound.

Find the time that elapses after the 8 kg particle hits the ground before the other two particles come to instantaneous rest. (You may assume this occurs before either particle reaches a pulley.)

[5]