

2 What is a power of 3.7 MW when expressed in kilowatts?

- A 3.7×10^{-3} kW
- B 3.7×10^{-3} KW
- C 3.7×10^3 kW
- D 3.7×10^3 KW

7

15 The total energy input E_{in} in a process is partly transferred to useful energy output U and partly transferred to energy that is wasted W .

What is the efficiency of the process?

- A $\frac{U}{E_{\text{in}}} \times 100\%$
- B $\frac{W}{E_{\text{in}}} \times 100\%$
- C $\frac{U}{W} \times 100\%$
- D $\frac{U+W}{E_{\text{in}}} \times 100\%$

5 A toy car travels on a circular track at a constant speed of 0.50 ms^{-1} . It passes a point on the track at time $t = 0$ and takes a time of 40 s to travel once around the track.

The magnitude of the average velocity of the car between $t = 0$ and $t = 20$ s is v_{20} .

The magnitude of the average velocity of the car between $t = 0$ and $t = 40$ s is v_{40} .

What are v_{20} and v_{40} ?

	v_{20}/ms^{-1}	v_{40}/ms^{-1}
A	0.32	0
B	0.32	0.32
C	0.50	0
D	0.50	0.50

18 A lamp is switched on for 2.0 hours. The power input to the lamp is 1.0 W. The energy given out by the lamp as light is 7.0×10^3 J.

How much energy is converted to other forms by the lamp?

- A 120 J
- B 200 J
- C 3400 J
- D 7200 J

4 Which statement about scalar and vector quantities is correct?

- A A scalar quantity has direction but not magnitude.
- B A scalar quantity has magnitude but not direction.
- C A vector quantity has direction but not magnitude.
- D A vector quantity has magnitude but not direction.

- 24 A miniature loudspeaker, initially at rest, falls vertically from a window in a high building. When the speaker has fallen a distance of 10.0 m, it emits a very short pulse of sound of constant frequency 256 Hz in all directions. The pulse of sound, travelling at a speed of 330 m s^{-1} , is heard by a person leaning out of the window.

Air resistance is negligible.

What is the frequency of the pulse of sound heard by the person?

- A 246 Hz B 249 Hz C 267 Hz D 313 Hz

- 17 A rock of mass 40 kg is released from rest from a height of 20 m above the surface of a planet.

The rock has a kinetic energy of 32 kJ when it hits the surface of the planet. The planet does not have an atmosphere.

What is the weight of the rock on the surface of the planet?

- A 1.6 N B 390 N C 1.6 kN D 64 kN

© UCLES 2022

9702/12/F/M/22

[Turn over

- 28 Light of a single wavelength is incident normally on a diffraction grating.

The resulting diffraction pattern is displayed on a screen.

Which change makes the first orders of intensity maxima further apart from each other on the screen?

- A placing the screen closer to the diffraction grating
B using a diffraction grating with less separation between adjacent slits
C using a diffraction grating with more slits but keeping the same separation between adjacent slits
D using light with a shorter wavelength

- 11 Two forces form a couple.

Which statement describes the two forces?

- A They are in the same direction.
B They are perpendicular to each other.
C They have the same magnitude.
D They pass through the same point.

11 A horizontal metal bar PQ of length 50.0 cm is hinged at end P. The diagram shows the metal bar viewed from above.

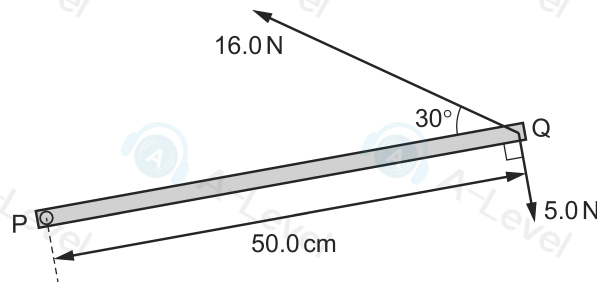

Two forces of 16.0 N and 5.0 N are in the horizontal plane and act on end Q, as shown.

What is the resultant moment about P due to the two forces?

- A 1.5 Nm B 4.4 Nm C 6.5 Nm D 9.4 Nm

© UCLES 2022

9702/12/F/M/22

[Turn over

4 An object is moving with an initial velocity of 4.0 m s^{-1} to the right. The velocity of the object changes so that its final velocity is 3.0 m s^{-1} downwards, as shown.



Which arrow represents the change in velocity of the object?

A

B

C

D

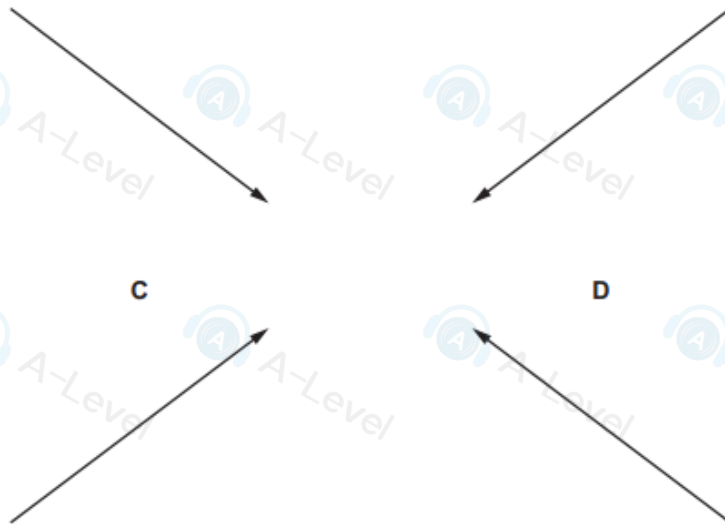

- 38 In an experiment on α -particle scattering, α -particles are directed at a thin gold foil. Most of the α -particles pass straight through the foil or are deflected by a small angle. A small number of α -particles are deflected by a large angle.

Which statement **cannot** be deduced from this experiment?

- A Atoms are mostly empty space.
 - B Most of the mass of an atom is concentrated in the nucleus.
 - C The nucleus of an atom contains protons.
 - D The nucleus of an atom is small compared to the size of an atom.
- 4 What is the difference between a scalar quantity and a vector quantity?
- A A scalar quantity has direction but a vector quantity does not.
 - B A scalar quantity has magnitude but a vector quantity does not.
 - C A vector quantity has direction but a scalar quantity does not.
 - D A vector quantity has magnitude but a scalar quantity does not.

- 19 An object of mass m is dropped onto the surface of two planets, X and Y, which have no atmosphere.

The height from which the object is dropped and the change in gravitational potential energy of the object, for each planet, are given in the table.

	height/m	change in gravitational potential energy
planet X	3	ΔE
planet Y	4	$4\Delta E$

The acceleration of free fall near the surface of planet X is g_x .

What is the acceleration of free fall near the surface of planet Y?

- A $\frac{3}{4}g_x$
 - B $\frac{4}{3}g_x$
 - C $3g_x$
 - D $4g_x$
-

- 17 A motor is used to lift a load vertically upwards.

The load has weight W .

The motor produces useful power output P .

The load is lifted at constant velocity v .

Which expression gives the time taken for the motor to lift the load vertically upwards through a distance d ?

- A $\frac{P}{Wd}$
- B $\frac{Wv}{P}$
- C $\frac{Wd}{P}$
- D $\frac{Pv}{W}$

30 The equation

$$\lambda = \frac{d \sin \theta}{n}$$

is used to calculate the wavelength λ of light in an experiment that uses a diffraction grating. The light from the diffraction grating is displayed on a screen.

What do the symbols n and d represent?

	n	d
A	number of slits in the grating	distance between adjacent slits in the grating
B	number of slits in the grating	distance from grating to screen
C	order of intensity maximum	distance between adjacent slits in the grating
D	order of intensity maximum	distance from grating to screen

12 A uniform rod is attached by a hinge at one end to a wall. The other end of the rod is supported by a wire so that the rod is horizontal and in equilibrium.

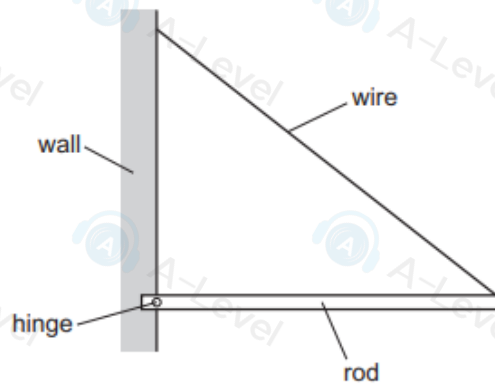

Which arrow shows the direction of the force on the rod from the hinge?

A



B



C



D



- 12 A cube WXZY has sides of length 2.0 cm and mass 24.0 g. The cube rests on a metre rule of negligible mass. The geometrical centre of the cube is vertically above the 70.0 cm mark on the scale of the rule.

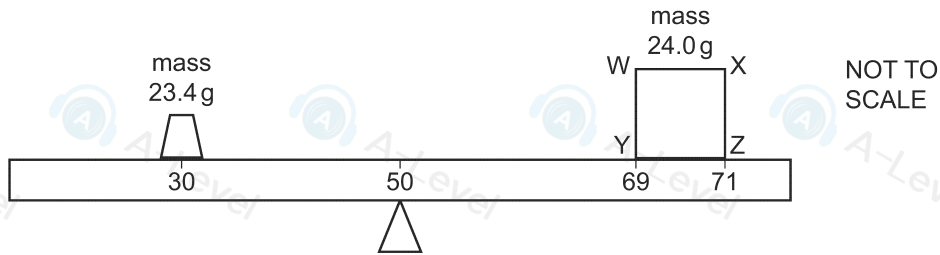

The cube has a non-uniform density so that its centre of gravity is **not** at its geometrical centre. The centre of gravity of the cube is in the plane of the diagram.

The rule rests on a pivot at the 50.0 cm mark. A mass of 23.4 g is placed vertically above the 30.0 cm mark. The rule is horizontal and in equilibrium.

What can be determined about the position of the centre of gravity of the cube?

- A It must be somewhere along a horizontal line that is 0.5 cm from line WX.
- B It must be somewhere along a horizontal line that is 0.5 cm from line YZ.
- C It must be somewhere along a vertical line that is 0.5 cm from line WY.
- D It must be somewhere along a vertical line that is 0.5 cm from line XZ.

- 30 Red light of a single wavelength passes through a diffraction grating. Bright dots are formed on a screen, as shown.



The red light is replaced with white light.

Which diagram, drawn to the same scale, shows a possible pattern of bright light on the screen?

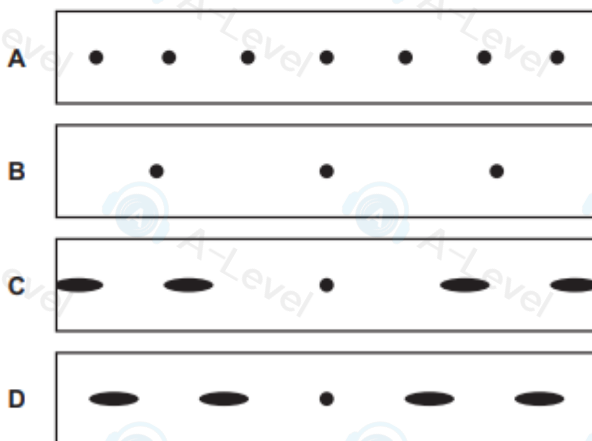

38 When α -particles are directed at gold leaf:

- 1 almost all α -particles pass through without deflection
- 2 a few α -particles are deviated through large angles.

What are the reasons for these effects?

	1	2
A	most α -particles have enough energy to pass right through the gold leaf	gold is very dense so a few low energy α -particles bounce back from the gold surface
B	most α -particles miss all gold atoms	a few α -particles bounce off gold atoms
C	the gold nucleus is very small so most α -particles miss all nuclei	occasionally the path of an α -particle is close to a nucleus
D	the positive charge in an atom is not concentrated enough to deflect an α -particle	occasionally an α -particle experiences many small deflections in the same direction

© UCLES 2022

9702/12/F/M/22

[Turn over

16 An escalator is 60 m long and lifts passengers through a vertical height of 30 m, as shown.

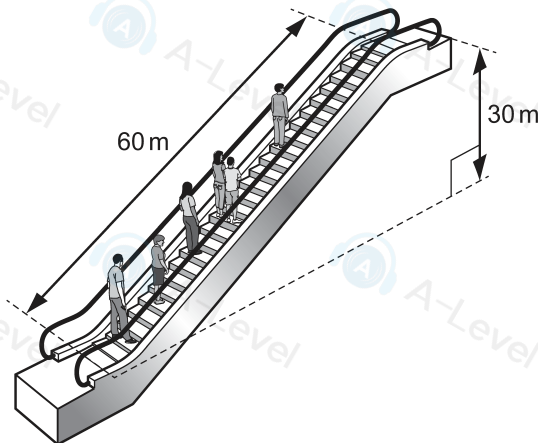

To drive the escalator against the forces of friction when there are no passengers requires a power of 2.0 kW.

The escalator is used by passengers of average mass 60 kg and the power to overcome friction remains constant.

How much power is required to drive the escalator when it is carrying 20 passengers and is travelling at 0.75 m s^{-1} ?

- A** 4.4 kW **B** 6.4 kW **C** 8.8 kW **D** 10.8 kW

- 24 A source emits a sound wave of a single frequency. The Doppler effect causes a different frequency of sound to be heard by a stationary observer.

What is a requirement for the Doppler effect to occur?

- A a source that is moving as it produces the sound wave
- B a source that produces a polarised sound wave
- C a source that produces a sound wave of changing amplitude
- D a source that produces a sound wave of changing frequency

- 13 A box of length 12 cm and weight 0.43 N is placed on a horizontal table, with the greater part of its length overhanging the edge of the table. The edge of the table acts as a pivot. The centre of gravity of the box is at its geometric centre.

To balance the box, a uniform sphere of diameter 2.4 cm is placed inside the box, touching one end, as shown.

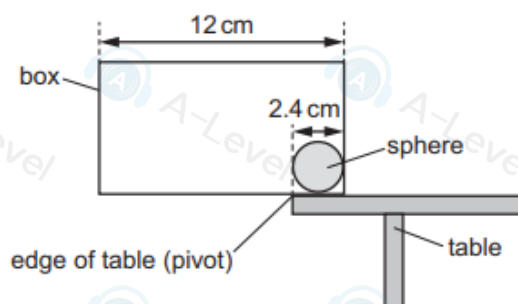

Assume that the forces acting on the box are in the plane of the diagram.

What is the minimum mass of the sphere that is needed to maintain the system in equilibrium?

- A 0.066 kg
- B 0.13 kg
- C 0.22 kg
- D 1.3 kg

- 38 In the α -particle scattering experiment, a beam of α -particles is aimed at a thin gold foil. Most of the α -particles go straight through or are deflected by a small angle. A very small proportion are deflected by more than 90° , effectively rebounding towards the source of the α -particles.

Which conclusion about the structure of atoms **cannot** be drawn from this experiment alone?

- A Most of the atom is empty space.
- B Most of the mass of an atom is concentrated in the nucleus.
- C The nucleus contains both protons and neutrons.
- D The nucleus is charged.

- 10 A rock of mass $2m$, travelling in deep space at velocity v , explodes into two parts of equal mass, one of which is then stationary.

What is the kinetic energy of the moving part after the explosion?

- A $\frac{1}{2}mv^2$
- B mv^2
- C $\frac{3}{2}mv^2$
- D $2mv^2$