

4.

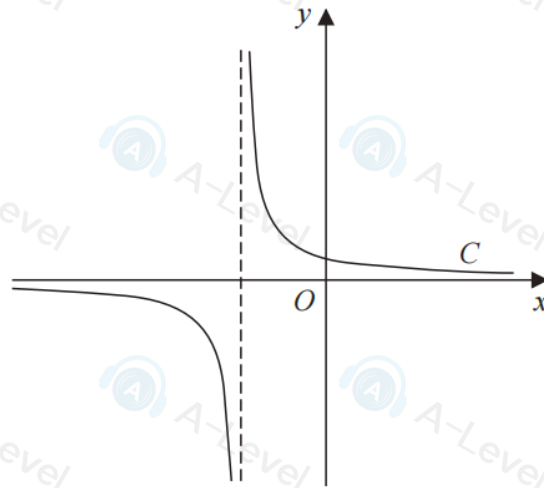

Figure 1

Figure 1 shows a sketch of part of the curve C with equation $y = \frac{1}{x+2}$

(a) State the equation of the asymptote of C that is parallel to the y -axis.

(1)

(b) Factorise fully $x^3 + 4x^2 + 4x$

(2)

A copy of Figure 1, labelled Diagram 1, is shown on the next page.

(c) On Diagram 1, add a sketch of the curve with equation

$$y = x^3 + 4x^2 + 4x$$

On your sketch, state clearly the coordinates of each point where this curve cuts or meets the coordinate axes.

(3)

(d) Hence state the number of real solutions of the equation

$$(x+2)(x^3 + 4x^2 + 4x) = 1$$

giving a reason for your answer.

(1)

DO NOT WRITE IN THIS AREA

DO NOT WRITE IN THIS AREA

DO NOT WRITE IN THIS AREA

4. The curve C has equation

$$y = \frac{2}{x} + 3x - 4 \quad x \neq 0$$

The straight line l has equation

$$y = kx + 2$$

where k is a constant.

- (a) Show that l meets C when

$$(k - 3)x^2 + 6x - 2 = 0 \quad (2)$$

- (b) Hence find the value of k for which l is a tangent to C

(3)

2. A tree was planted.

Exactly 3 years after it was planted, the height of the tree was 2 m.

Exactly 5 years after it was planted, the height of the tree was 2.4 m.

Given that the height, H metres, of the tree, t years after it was planted, can be modelled by the equation

$$H^3 = pt^2 + q$$

where p and q are constants,

- (a) find, to 3 significant figures where necessary, the value of p and the value of q .

(4)

Exactly T years after the tree was planted, its height was 5 m.

- (b) Find the value of T according to the model, giving your answer to one decimal place.

(2)

blank

3.

**Figure 1**

Figure 1 shows the plan of a garden. The marked angles are right angles.

The six edges are straight lines.

The lengths shown in the diagram are given in metres.

Given that the perimeter of the garden is greater than 29 m,

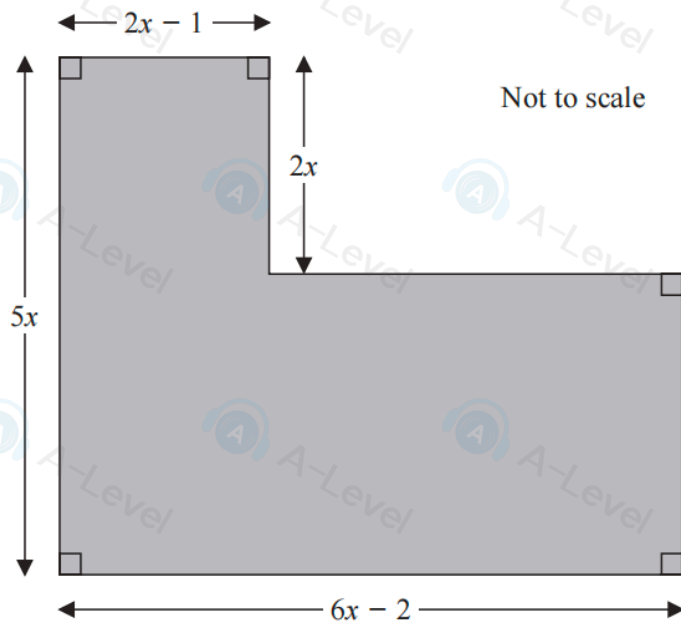
(a) show that $x > 1.5$ m

(3)

Given also that the area of the garden is less than 72 m^2 ,

(b) form and solve a quadratic inequality in x .

(5)

(c) Hence state the range of possible values of x .

(1)

2. The points P , Q and R have coordinates $(-3, 7)$, $(9, 11)$ and $(12, 2)$ respectively.

(a) Prove that angle $PQR = 90^\circ$

(3)

Given that the point S is such that $PQRS$ forms a rectangle,

(b) find the coordinates of S .

(2)

DO NOT WRITE IN THIS AREA

DO NOT WRITE IN THIS AREA

DO NOT

DO NOT WRITE IN

9.

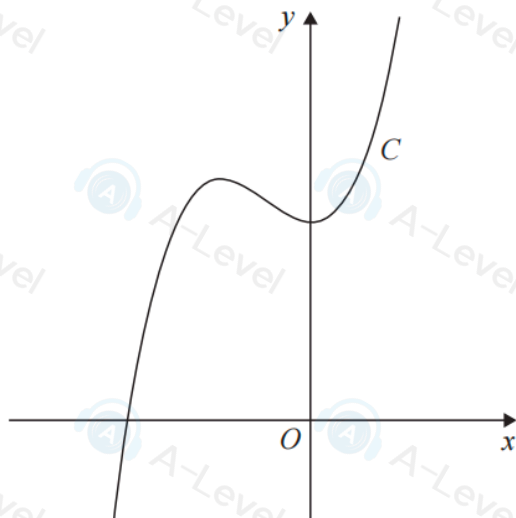

Figure 4

Figure 4 shows a sketch of the curve C with equation $y = f(x)$, where

$$f(x) = (x + 5)(3x^2 - 4x + 20)$$

(a) Deduce the range of values of x for which $f(x) \geq 0$ (1)

(b) Find $f'(x)$ giving your answer in simplest form. (3)

The point $R(-4, 84)$ lies on C .

Given that the tangent to C at the point P is parallel to the tangent to C at the point R

(c) find the x coordinate of P . (4)

(d) Find the point to which R is transformed when the curve with equation $y = f(x)$ is transformed to the curve with equation,

(i) $y = f(x - 3)$

(ii) $y = 4f(x)$ (2)

5.

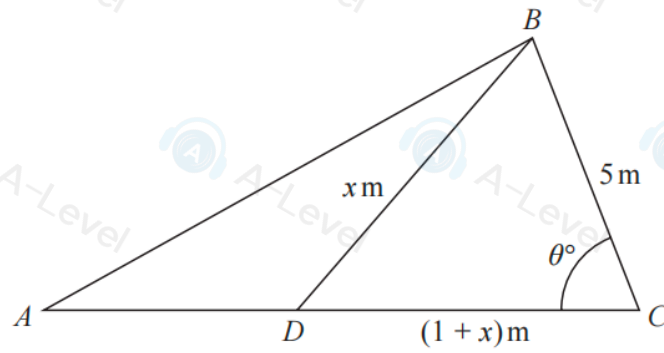

Diagram NOT
accurately drawn

Figure 2

Figure 2 shows the plan view of a frame for a flat roof.

The shape of the frame consists of triangle ABD joined to triangle BCD .

Given that

- $BD = x$ m
- $CD = (1 + x)$ m
- $BC = 5$ m
- angle $BCD = \theta^\circ$

(a) show that $\cos \theta^\circ = \frac{13 + x}{5 + 5x}$

(2)

Given also that

- $x = 2\sqrt{3}$
- angle $BAC = 30^\circ$
- ADC is a straight line

(b) find the area of triangle ABC , giving your answer, in m^2 , to one decimal place.

(5)

DO NOT WRITE IN THIS AREA

DO NOT WRITE IN THIS AREA

DO NOT WRITE IN THIS AREA

DO NOT WRITE IN THIS AREA

DO NOT WRITE IN THIS AREA

DO NOT WRITE IN THIS AREA

1. Find

$$\int (2x - 5)(3x + 2)(2x + 5) dx$$

writing your answer in simplest form.

(5)

8. In this question you must show all stages of your working.

Solutions relying entirely on calculator technology are not acceptable.

(a) Find the equation of the tangent to the curve with equation

$$y = \frac{1}{4}x^3 - 8x^{\frac{1}{2}}$$

at the point $P(4, 12)$

Give your answer in the form $ax + by + c = 0$ where a , b and c are integers.

(5)