

1 Which of the following is a vector quantity?

- A work done
 B time
 C temperature
 D displacement

(Total for Question 1 = 1 mark)

8 A student is determining the acceleration of free-fall, g .

The student uses a stopwatch to measure the time taken for a ball bearing to fall a measured distance.

The student calculates a value of g that is greater than 9.81 m s^{-2} .

Which of the following could be an explanation for the student's result?

- A The ball bearing is moving downwards when the student starts the stopwatch.
 B The ball bearing is moving upwards when the student starts the stopwatch.
 C The student starts the stopwatch before the ball bearing is dropped.
 D The student stops the stopwatch after the ball bearing lands.

(Total for Question 8 = 1 mark)

9 The stiffness constant and the Young modulus are terms used in physics.

Which row of the table shows the correct application of these terms?

	Stiffness constant applies to	Young modulus applies to
<input type="checkbox"/> A	materials	materials
<input type="checkbox"/> B	objects	objects
<input type="checkbox"/> C	materials	objects
<input type="checkbox"/> D	objects	materials

(Total for Question 9 = 1 mark)

4 A ball of mass m is projected vertically upwards. An air resistance F acts on the ball at all times.

Which of the following equations would apply to the ball as it is travelling upwards?

- A $mg - F = 0$
 B $mg + F = 0$
 C $mg - F = ma$
 D $mg + F = ma$

(Total for Question 4 = 1 mark)

19 A large parasol has been set up on a windy day. The centre of gravity of the parasol is vertically above the centre of the base. The bottom of the parasol starts to lift from the ground as shown. The weight of the parasol is 110 N.

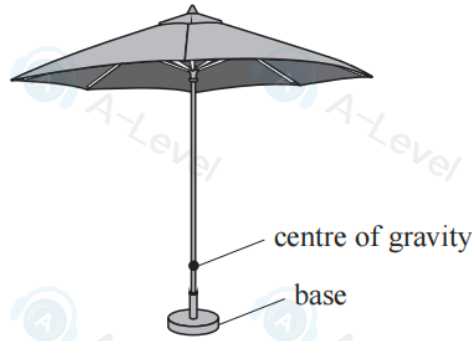

(a) The force of the wind is 14 N in a horizontal direction.

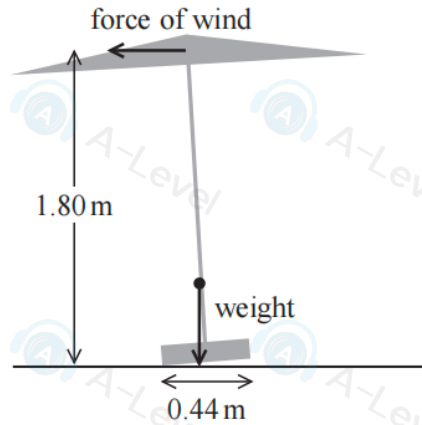

Explain why the parasol will topple. Your answer should include a calculation.

(4)

DO NOT WRITE IN THIS AREA

DO NOT WRITE IN THIS AREA

DO NOT WRITE

- (b) To prevent the parasol from toppling, a rope is attached to the parasol at 1.50 m from the ground as shown. The rope makes an angle of 44° to the vertical.

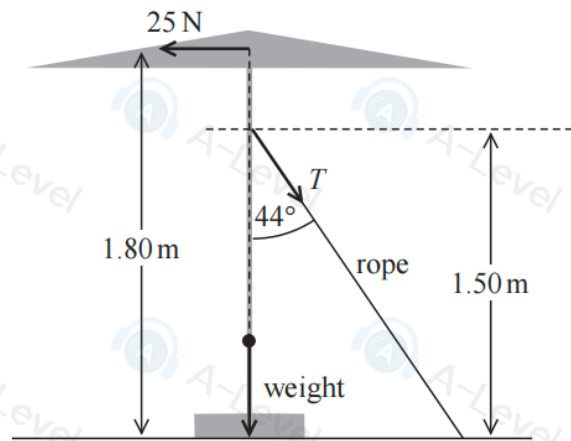

The horizontal force from the wind is now 25 N.

Determine, by taking moments about the centre of the base, the vertical force that the base exerts on the ground.

Assume that the force which the ground exerts on the base acts through the midpoint of the base.

(5)

Force exerted on the ground =

(Total for Question 19 = 9 marks)

18 A uniform door of width w is supported by two hinges, X and Y. X and Y are a vertical distance L apart as shown.

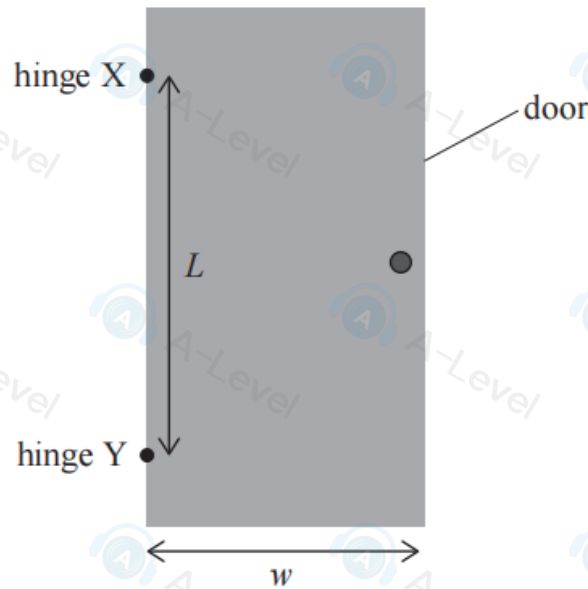

(a) State the conditions needed for the door to be in equilibrium.

(2)

(b) Give the meaning of the term centre of gravity.

(1)

18 A uniform door of width w is supported by two hinges, X and Y. X and Y are a vertical distance L apart as shown.

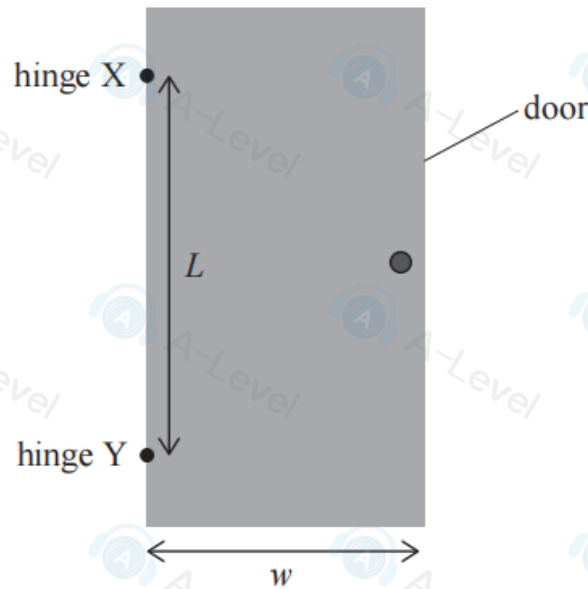

(a) State the conditions needed for the door to be in equilibrium.

(2)

(b) Give the meaning of the term centre of gravity.

(1)

(iii) An identical door is supported by hinges that are much closer together.

Explain how a smaller value of L affects F and θ .

You should consider moments about point X.

(4)

(Total for Question 18 = 16 marks)

14 A grain of sand quickly reaches terminal velocity when it falls into water.

(a) State why the grain of sand reaches terminal velocity.

(1)

(b) A spherical grain of sand has a weight of 4.3×10^{-5} N. The grain of sand displaces water with a weight of 1.5×10^{-5} N.

The terminal velocity of the grain of sand as it falls through the water is about 0.050 m s^{-1} .

Deduce whether Stokes' law applies to the grain of sand as it falls at terminal velocity.

viscosity of water = $1.2 \times 10^{-3} \text{ Pa s}$

diameter of grain of sand = $1.5 \times 10^{-3} \text{ m}$

(3)

(c) Explain how the temperature of the water affects the terminal velocity of a grain of sand if Stokes' law does apply.

(2)

(Total for Question 14 = 6 marks)

14 A grain of sand quickly reaches terminal velocity when it falls into water.

(a) State why the grain of sand reaches terminal velocity.

(1)

(b) A spherical grain of sand has a weight of 4.3×10^{-5} N. The grain of sand displaces water with a weight of 1.5×10^{-5} N.

The terminal velocity of the grain of sand as it falls through the water is about 0.050 m s^{-1} .

Deduce whether Stokes' law applies to the grain of sand as it falls at terminal velocity.

viscosity of water = $1.2 \times 10^{-3} \text{ Pa s}$

diameter of grain of sand = $1.5 \times 10^{-3} \text{ m}$

(3)

(c) Explain how the temperature of the water affects the terminal velocity of a grain of sand if Stokes' law does apply.

(2)

(Total for Question 14 = 6 marks)

14 A grain of sand quickly reaches terminal velocity when it falls into water.

(a) State why the grain of sand reaches terminal velocity.

(1)

(b) A spherical grain of sand has a weight of 4.3×10^{-5} N. The grain of sand displaces water with a weight of 1.5×10^{-5} N.

The terminal velocity of the grain of sand as it falls through the water is about 0.050 m s^{-1} .

Deduce whether Stokes' law applies to the grain of sand as it falls at terminal velocity.

viscosity of water = $1.2 \times 10^{-3} \text{ Pa s}$

diameter of grain of sand = $1.5 \times 10^{-3} \text{ m}$

(3)

(c) Explain how the temperature of the water affects the terminal velocity of a grain of sand if Stokes' law does apply.

(2)

(Total for Question 14 = 6 marks)